



Korta

**HUSILLOS A BOLAS
BALLSCREWS**

**CATALOGO DIMENSIONAL
DIMENSIONAL CATALOGUE**





KORTA S.A. atesora una larga experiencia en el diseño, producción y comercialización de husillos a bolas. Nuestro constante esfuerzo en la búsqueda del más alto nivel de CALIDAD hace que podamos ofrecer al mercado un producto de calidad contrastada a nivel internacional.

KORTA S.A. utiliza avanzados medios y tecnologías punteras de fabricación, sistemas informáticos y de CAD/CAM aplicados a la producción de husillos a bolas.

KORTA S.A. con una clara política de aseguramiento de CALIDAD, dispone del Certificado de Registro de Empresa ER-071/2/96 de acuerdo con la norma UNE-EN ISO 9002.

KORTA S.A. formado por un conjunto de PERSONAS altamente cualificadas, ofrece al mercado una vocación de SERVICIO pensada en el cliente, dando adecuadas soluciones a sus necesidades y respuesta rápida a todo tipo de aplicaciones.

INTRODUCCION INTRODUCTION

KORTA S.A. has been accumulating experience of the design, production and sales of ball screws for many years. Our ongoing effort to attain the highest level of QUALITY has enabled us to put an internationally approved quality product on the market.

To make it, KORTA S.A. uses state-of-the-art production means, vanguard technologies, CAD/CAM and other computing systems specially adapted to the production of ball screws.

KORTA S.A. also implements a plain Quality Assurance policy that has won us the Registered Firm Certificate No. ER-071/2/96 for compliance with the UNE-EN ISO 9002 standard.

KORTA S.A., staffed by a team of highly skilled PEOPLE, offers their customer-orientated SERVICE vocation to the market and provides adequate solutions to any demands and a quick response to all sorts of applications.



ISO 9002

Gama de fabricación

Production Range



Diámetro Diameter	Paso Lead												
	4	5	6	8	10	12	16	20	25	32	40	50	64
12													
16													
20													
25													
32													
40													
50													
63													
80													
100													
120													

■ Pasos normalizados DIN
DIN standard leads

La tabla muestra las medidas más usuales en la fabricación de husillos a bolas KORTA. Para la posibilidad de cualquier otra medida consultar con el departamento técnico de KORTA.

The table shows the most common sizes used in the manufacturing of KORTA ball screws. Please contact KORTA's Engineering Department about the possibility of dealing with other sizes.

Stock de husillos a bolas KORTA

Stock of KORTA Ball screws

Con el objetivo de minimizar el plazo de entrega de los husillos a bolas, KORTA ofrece una gama de medidas en stock. Esta gama en stock se divide en husillos según norma propia KORTA y según norma DIN 69051.

In order to minimize the delivery times, KORTA offers a range of ball screws in several sizes from permanent stocks. The said range comprises ball screws according to both KORTA's own standard and the DIN 69051 standard.

En ambos casos los husillos se dividirán en husillos laminados y husillos rectificados. Los husillos laminados son muy apropiados para aplicaciones en las que las prestaciones que se exigen a este mecanismo, no son tan elevadas como en el caso de los husillos a bolas rectificados. En la fabricación de estos primeros ya no se incluye la operación de rectificado de rosca del husillo, (aunque sí el rectificado de rosca de la tuerca) y por consiguiente se obtiene un sustancial abaratamiento de su costo de fabricación y precio de venta.

Each category is further divided into rolled ball screws and ground ball screws. Rolled ball screws are suitable for any application demanding a level of performance from this system, which need not be as high as that required from ground ball screws. Manufacturing of the former type excludes the grinding of the screw thread (but not of the nut thread); it ensues a substantial cutdown of this product manufacturing costs and selling price.

Grados de precisión

Accuracy grade

DIN, ISO			IT1		IT3		IT5		IT7	IT10
JIS	C0	C1		C3		C5		C7		C10
V _{300p} (µm)	3,5	5	6	8	12	18	23	50	52	210

Husillos a bolas laminados y rectificados

Rolled and Ground Ball Screws

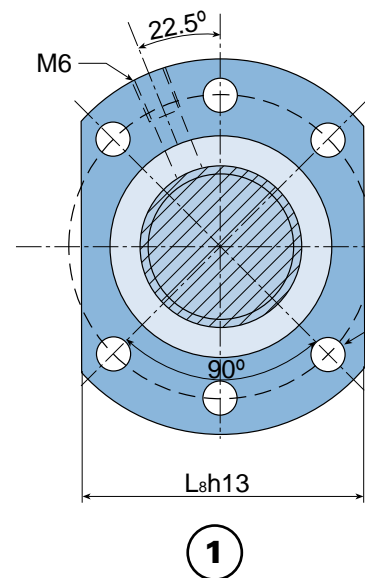
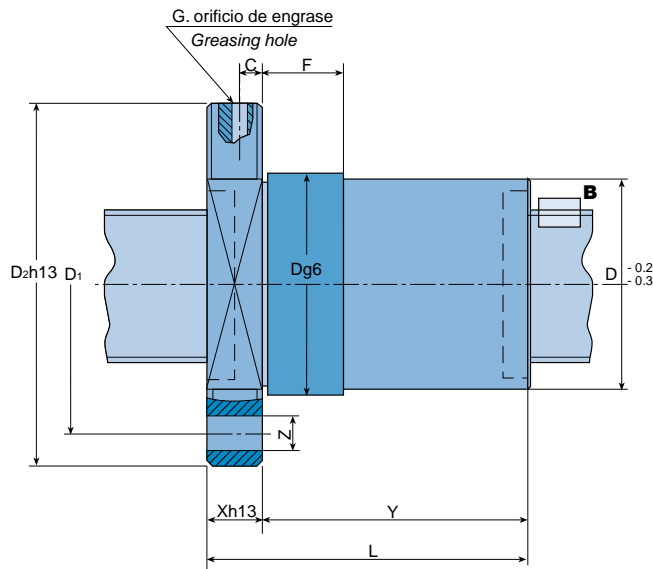

TUERCA SIMPLE CON BRIDA

Tipo : KBS

SINGLE NUT WITH FLANGE

Type: KBS

Referencia Type	Diámetro Diameter (d_0)	Paso Lead (Ph)	Diam. bolas Ball diameter (D_w)	Circuitos Circuits (i)	D_{pw}	d_2	Laminados / Rolled B.S.			Rectificados / Ground B.S.				
							$C_0(N)$	$C_A(N)$	Juego axial Backlash	$R_{s1}(N/\mu m \cdot m)$	$R_{nu}(N/\mu m)$	$C_0(N)$	$C_A(N)$	Juego axial Backlash
KBS-1605	16	5	3,5	2	17	13,5	10881	5759	0,05	34,8	116,3	12090	6399	0,03
KBS-2005	20	5	3,5	3	21	17,5	20804	9323	0,05	56,6	209,1	23116	10359	0,03
KBS-2505	25	5	3,5	3	26	22,5	28262	10985	0,05	91,3	261,1	31402	12205	0,03
KBS-2510		10	4,762	3	26,6	21,84	35609	15594	0,05	89	264,8	39566	17327	
KBS-2520		20	3,5	2	26	22,5	21230	8470	0,05	91,3	208	23589	9411	
KBS-3205	32	5	3,5	4	33	29,5	49618	16012	0,05	153,7	420,6	55131	17791	0,03
KBS-3210		10	6,35	3	34,1	27,75	58610	24978	0,05	144,6	317,6	65122	27753	
KBS-3220		20	3,969	3	33,3	29,33	46431	15881	0,05	153,3	389,5	51590	17645	
KBS-3232		32	3,969	2	33,3	29,33	30543	11205	0,05	153,3	259,4	33937	12450	
KBS-4005	40	5	3,5	5	41	37,5	79421	21656	0,05	244,7	624,6	88245	24062	0,03
KBS-4010		10	6,35	4	42,1	35,75	104351	37477	0,05	233,3	528,8	115945	41641	
KBS-4020		20	6,35	3	40,1	33,75	90435	32612	0,05	209,1	462,6	100483	36235	
KBS-4040		40	6,35	2	40,1	33,75	56104	22195	0,05	209,1	302,9	62338	24661	
KBS-5005	50	5	3,5	5	51	47,5	101785	24095	0,05	388,3	731,7	113094	26772	0,03
KBS-5010		10	7,144	5	52	44,86	185917	59639	0,05	363,5	784,8	206574	66265	
KBS-5020		20	7,144	5	50	42,86	217622	66900	0,05	333,2	928,3	241802	74333	
KBS-6305	63	5	3,5	5	64	60,5	131599	26836	0,05	624,2	849,4	146221	29818	0,03
KBS-6310		10	7,144	5	65	57,86	248055	68776	0,05	592,6	958,6	275617	76418	
KBS-6320		20	7,144	5	65	57,86	280126	74672	0,05	592,6	1156,9	311251	82969	

• Standard únicamente rosca derecha. Rosca izquierda bajo consulta.

• R_{s1} = Rigidez del eje del husillo a bolas en el caso de un extremo fijo y otro libre por 1m de longitud. Para el caso de los dos extremos fijos multiplicar por 4.

• R_{nu} = Rigidez de la tuerca para una carga de servicio media del 30% de la capacidad de carga dinámica y una calidad IT5.

DIN 69051

STOCK

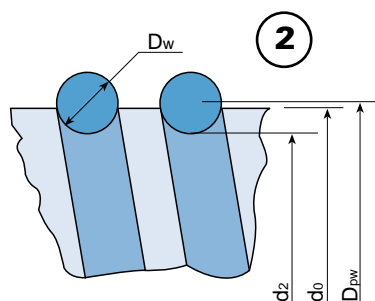
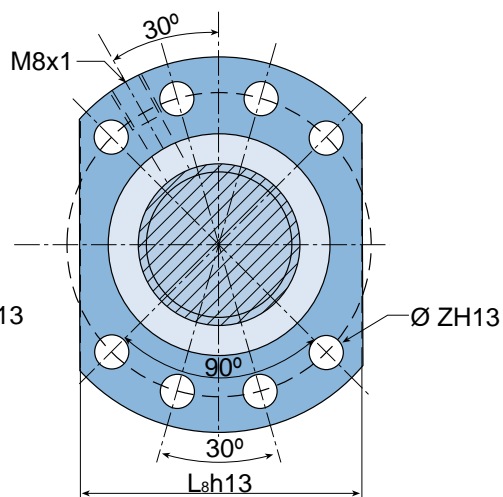

Detalle B
Detail B

Paso
Lead

Diámetro Diameter	5	10	20	32	40
16	KBS				
20	KBS				
25	KBS	KBS	KBS		
32	KBS	KBS	KBS	KBS	
40	KBS	KBS	KBS		KBS
50	KBS	KBS	KBS		
63	KBS	KBS	KBS		

DIN 69051/5

DIN 69051/2

Paso no normalizado / Non standard lead

unidades en mm / units: mm

Dimensiones de la tuerca / Nut dimensions											Referencia Type
D	D ₁	D ₂	X	Y	L	L _s	Tipo/Type	Z	C	F	
28	38	48	10	28	38	40	①	5,5	5	10	KBS-1605
36	47	58	10	33	43	44	①	6,6	5	10	KBS-2005
40	51	62	10	33	43	48	①	6,6	5	10	KBS-2505
				55	65					16	KBS-2510
				59	69					25	KBS-2520
50	65	80	12	38	50	62	①	9	6	10	KBS-3205
				63	75					16	KBS-3210
				87	99					25	KBS-3220
				86	101					40	KBS-3232
63	78	93	14	43	57	70	②	9	7	10	KBS-4005
				74	88					16	KBS-4010
				88	102					25	KBS-4020
				106	120					45	KBS-4040
75	93	110	16	43	59	85	②	11	8	10	KBS-5005
				84	100					16	KBS-5010
				127	143					25	KBS-5020
90	108	125	18	43	61	95	②	11	9	10	KBS-6305
				84	102					16	KBS-6310
95	115	135	20	124	144	100		13,5	10	25	KBS-6320

• Standard thread RH only. Left-hand thread on request.

• R_{s1} = Rigidity of the ball screw shaft with one end fixed and one end free, per unit length of one metre. For two-end fixed systems, multiply by 4.

• R_{nu} = Rigidity of the nut for a working load equal to 30% of the dynamic load rating and for a tolerance grade of IT5.

Husillos a bolas rectificados

Ground Ball Screws

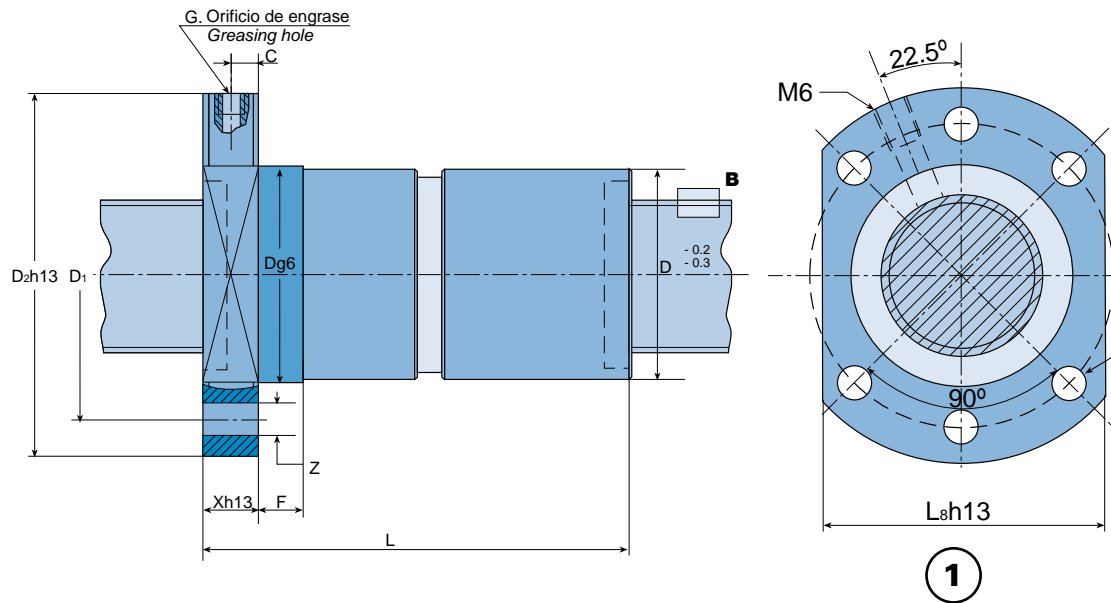

TUERCA DOBLE CON BRIDA

Tipo : EDBS

DOUBLE NUT WITH FLANGE

Type: EDBS

Referencia Type	Diámetro Diameter (d ₀)	Paso Lead (Ph)	Diam. bolas Ball diameter (Dw)	Circuitos Circuits (i)	D _{pw}	d ₂	Capacidad de carga Load rating		Rigidez / Rigidity		Dimensiones			
							C ₀ (N)	C _A (N)	R _{S1} (N/μm-m)	R _{nu} (N/μm)	D	D ₁	D ₂	X
EDBS-1605	16	5	3,5	2	17	13,5	12090	6399	34,8	130,8	28	38	48	10
EDBS-2005	20	5	3,5	3	21	17,5	23116	10359	56,6	235,7	36	47	58	10
EDBS-2505	25	5	3,5	3	26	22,5	31402	12205	91,3	297,2	40	51	62	10
EDBS-2510		10	4,762	3	26,6	21,84	39566	17327	89,0	297,4				
EDBS-2520		20	3,5	2	26	22,5	23589	9411	91,3	231,6				
EDBS-3205	32	5	3,5	4	33	29,5	55131	17791	153,7	481,8	50	65	80	12
EDBS-3210		10	6,35	3	34,1	27,75	65122	27753	144,6	358,5				
EDBS-3220		20	3,969	3	33,3	29,33	51590	17645	153,3	436,1				
EDBS-3232		32	3,969	2	33,3	29,33	33937	12450	153,3	288,3				
EDBS-4005	40	5	3,5	5	41	37,5	88245	24062	244,7	718,9	63	78	93	14
EDBS-4010		10	6,35	4	42,1	35,75	115945	41641	233,3	598,6				
EDBS-4020		20	6,35	3	40,1	33,75	100483	36235	209,1	517,3				
EDBS-4040		40	6,35	2	40,1	33,75	62338	24661	209,1	336,4				
EDBS-5005	50	5	3,5	5	51	47,5	113094	26772	388,3	851,2	75	93	110	16
EDBS-5010		10	7,144	5	52	44,86	206574	66265	363,5	894,8				
EDBS-5020		20	7,144	5	50	42,86	241802	74333	333,2	1042,4				
EDBS-6305	63	5	3,5	5	64	60,5	146221	29818	624,2	1002,2	90	108	125	18
EDBS-6310		10	7,144	5	65	57,86	275617	76418	592,6	1104,3				
EDBS-6320		20	7,144	5	65	57,86	311251	82969	592,6	1305,1				
EDBS-8010	80	10	7,144	6	82	74,856	441184	102213	976,4	1564,5	105	125	145	20
EDBS-8020		20	9,525	5	82,6	73,075	533922	137429	949,1	1644,1	125	145	165	25

• Standard unicamente rosca derecha. Rosca izquierda bajo consulta.

• R_{S1}= Rigidez del eje del husillo a bolas en el caso de un extremo fijo y otro libre por 1m de longitud. Para el caso de los dos extremos fijos multiplicar por 4.

• R_{nu}=Rigidez de la tuerca con una precarga del 6% de la capacidad de carga dinámica y una calidad IT5.

DIN 69051

STOCK

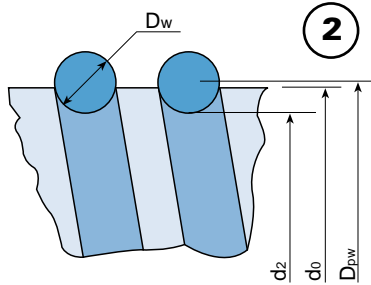
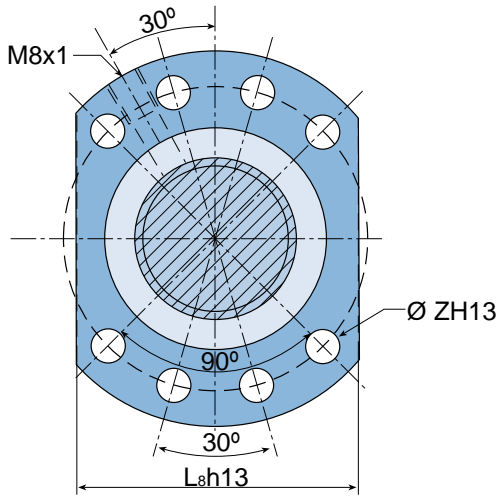

Detalle B
Detail B

unidades en mm / units: mm

Diámetro Diameter	Paso Lead				
	5	10	20	32	40
16	EDBS				
20	EDBS				
25	EDBS	EDBS	EDBS		
32	EDBS	EDBS	EDBS	EDBS	
40	EDBS	EDBS	EDBS		EDBS
50	EDBS	EDBS	EDBS		
63	EDBS	EDBS	EDBS		
80		EDBS	EDBS		

DIN 69051/5

DIN 69051/2

Paso no normalizado / Non standard lead

de la tuerca / Nut dimensions						Referencia Type
L	L _s	Tipo/Type	Z	C	F	
66	40	①	5,5	5	10	EDBS-1605
76	44	①	6,6	5	10	EDBS-2005
76	48	①	6,6	5	10	EDBS-2505
120					16	EDBS-2510
133					25	EDBS-2520
88	62	①	9	6	10	EDBS-3205
133					16	EDBS-3210
183					25	EDBS-3220
187					40	EDBS-3232
100	70	②	9	7	10	EDBS-4005
157					16	EDBS-4010
189					25	EDBS-4020
225					45	EDBS-4040
102	85	②	11	8	10	EDBS-5005
179					16	EDBS-5010
271					25	EDBS-5020
104	95	②	11	9	10	EDBS-6305
181					16	EDBS-6310
273	100	②	13,5	10	25	EDBS-6320
205	110		10	16	EDBS-8010	
276	130		12,5	25	EDBS-8020	

• Standard thread RH only. Left-hand thread on request.

• R_{s1}= Rigidity of the ball screw shaft with one end fixed and one end free, per unit length of one metre. For two-end fixed systems, multiply by 4.

• R_{nu}= Rigidity of the nut preloaded to 6% of the dynamic load rating and for a tolerance grade of IT5.

Husillos a bolas laminados y rectificados

Rolled and Ground Ball Screws

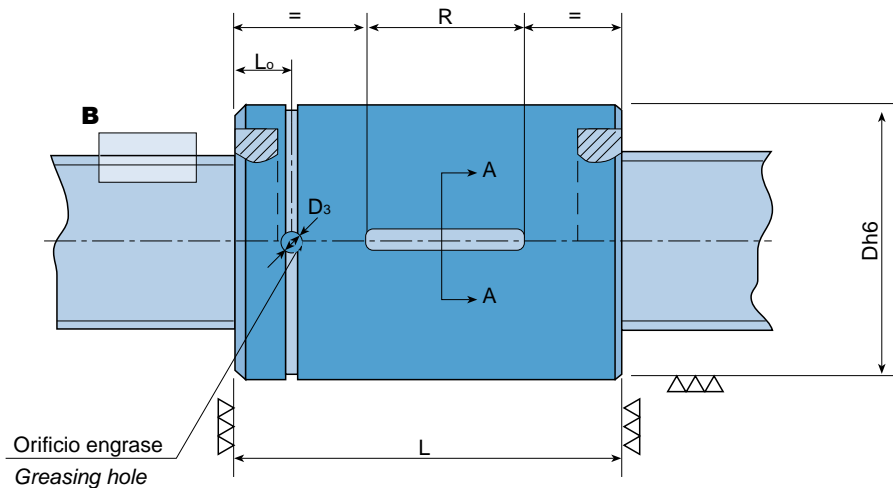

TUERCA SIMPLE SIN BRIDA

Tipo : RS
SINGLE NUT WITHOUT FLANGE
Type: RS

Referencia Type	Diámetro Diameter (d_0)	Paso Lead (Ph)	Diam. bolas Ball diameter (D_w)	Circuitos Circuits (i)	D_{pw}	d_2	Laminados / Rolled B.S.			Rectificados / Ground B.S.				
							C_0 (N)	C_A (N)	Juego axial Backlash	R_{s1} (N/ μ m-m)	R_{nu} (N/ μ m)	C_0 (N)	C_A (N)	Juego axial Backlash
RS-2005	20	5	3,5	3	21	17,5	20804	9323	0,05	56,6	208,4	23116	10359	0,03
RS-2505	25	5	3,5	3	26	22,5	28262	10985	0,05	91,3	261,1	31402	12205	0,03
RS-2510		10	6,35	3	27,1	20,75	43847	21055	0,05	84,3	211,7	48719	23394	
RS-3205	32	5	3,5	4	33	29,5	49618	16012	0,05	153,7	415,6	55131	17791	0,03
RS-3210		10	6,35	3	34,1	27,75	58610	24978	0,05	144,6	267	65122	27753	
RS-4005	40	5	3,5	5	41	37,5	79421	21656	0,05	244,7	597,1	88245	24062	0,03
RS-4010		10	6,35	4	42,1	35,75	104351	37477	0,05	233,3	439	115945	41641	
RS-5005	50	5	3,5	5	51	47,5	101785	24095	0,05	388,3	708,6	113094	26772	0,03
RS-5010		10	7,144	5	52	44,86	185917	59639	0,05	363,5	625,9	206574	66265	
RS-6310	63	10	7,144	5	65	57,86	248055	68776	0,05	592,6	758,7	275617	76418	0,03

- Standard unicamente rosca derecha. Rosca izquierda bajo consulta.
- R_{s1} = Rigidez del eje del husillo a bolas en el caso de un extremo fijo y otro libre por 1m de longitud. Para el caso de los dos extremos fijos multiplicar por 4.
- R_{nu} = Rigidez de la tuerca para una carga de servicio media del 30% de la capacidad de carga dinámica y una calidad IT5.

STOCK

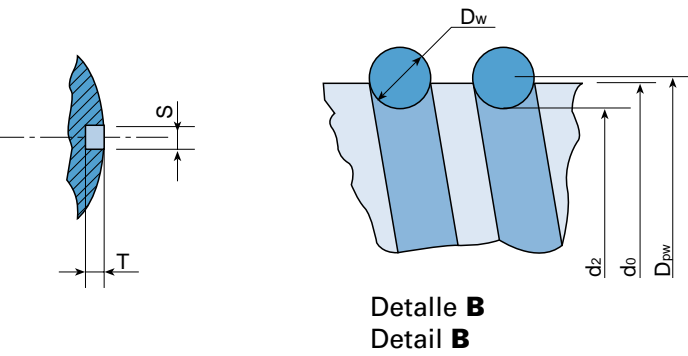

Paso
Lead

Diámetro Diameter	5	10	20	40
16				
20	RS			
25	RS	RS		
32	RS	RS		
40	RS	RS		
50	RS	RS		
63		RS		

unidades en mm / units: mm

Dimensiones de la tuerca / Nut dimensions							Referencia Type
D	L	R	S	T	D ₃	L ₀	
35	44	16	5	2	2,5	9	RS-2005
40	45	16	5	2	3	9	RS-2505
48	79	25				13	RS-2510
48	50	20	6	2,5	3	9	RS-3205
54	79	25				13	RS-3210
56	55	20	6	2,5	3,5	9	RS-4005
62	91	25				14	RS-4010
70	56	20	6	2,5	4	10	RS-5005
72	102	25				15	RS-5010
85	102	25	6	2,5	4	15	RS-6310

- Standard thread RH only. Left-hand thread on request.
- R_{s1}= Rigidity of the ball screw shaft with one end fixed and one end free, per unit length of one metre. For two-end fixed systems, multiply by 4.
- R_{nu}= Rigidity of the nut for a working load equal to 30% of the dynamic load rating and for a tolerance grade of IT5.

Husillos a bolas laminados y rectificados

Rolled and Ground Ball Screws

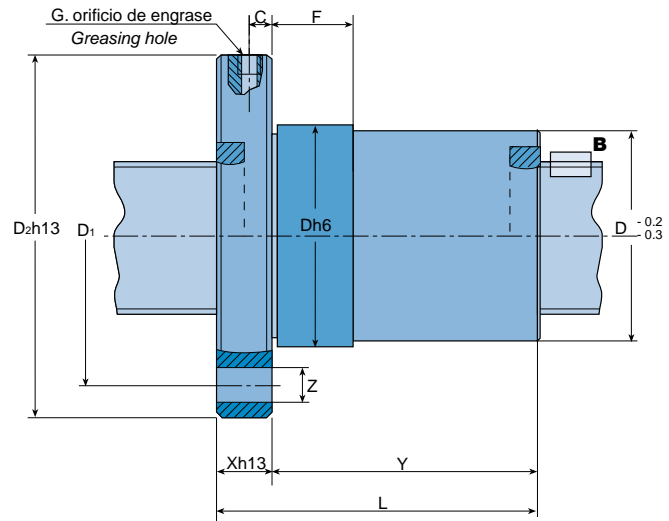

TUERCA SIMPLE CON BRIDA

Tipo : RBS

SINGLE NUT WITH FLANGE

Type: RBS

Referencia Type	Diámetro Diameter (d ₀)	Paso Lead (Ph)	Diam. bolas Ball diameter (D _w)	Circuitos Circuits (i)	D _{pw}	d ₂	Laminados / Rolled B.S.			Rectificados / Ground B.S.				
							C ₀ (N)	C _A (N)	Juego axial Backlash	R _{s1} (N/μm·m)	R _{nu} (N/μm)	C ₀ (N)	C _A (N)	Juego axial Backlash
RBS-2005	20	5	3,5	3	21	17,5	20804	9323	0,05	56,6	208,4	23116	10359	0,03
RBS-2505	25	5	3,5	3	26	22,5	28262	10985	0,05	91,3	261,1	31402	12205	0,03
RBS-2510		10	6,35	3	27,1	20,75	43847	21055	0,05	84,3	211,7	48719	23394	
RBS-3205	32	5	3,5	4	33	29,5	49618	16012	0,05	153,7	415,6	55131	17791	0,03
RBS-3210		10	6,35	3	34,1	27,75	58610	24978	0,05	144,6	267,0	65122	27753	
RBS-4005	40	5	3,5	5	41	37,5	79421	21656	0,05	244,7	597,1	88245	24062	0,03
RBS-4010		10	6,35	4	42,1	35,75	104351	37477	0,05	233,3	439,0	115945	41641	
RBS-5005	50	5	3,5	5	51	47,5	101785	24095	0,05	388,3	708,6	113094	26772	0,03
RBS-5010		10	7,144	5	52	44,86	185917	59639	0,05	363,5	625,9	206574	66265	
RBS-6310	63	10	7,144	5	65	57,86	248055	68776	0,05	592,6	758,7	275617	76418	0,03

• Standard únicamente rosca derecha. Rosca izquierda bajo consulta.

• R_{s1}= Rigidez del eje del husillo a bolas en el caso de un extremo fijo y otro libre por 1m de longitud. Para el caso de los dos extremos fijos multiplicar por 4.

• R_{nu}= Rigidez de la tuerca para una carga de servicio media del 30% de la capacidad de carga dinámica y una calidad IT5.

STOCK

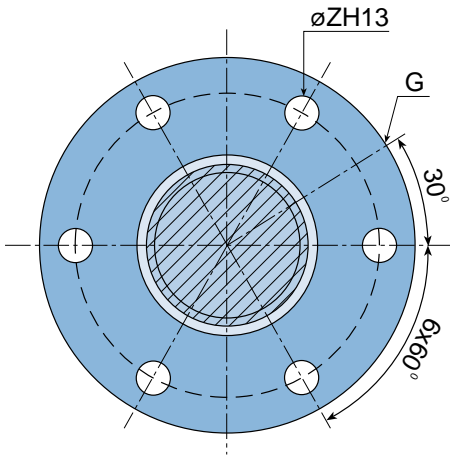

Paso
Lead

Diámetro Diameter	5	10	20	40
16				
20	RBS			
25	RBS	RBS		
32	RBS	RBS		
40	RBS	RBS		
50	RBS	RBS		
63		RBS		

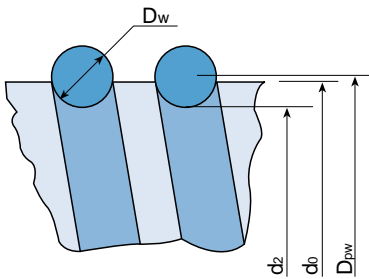

Detalle **B**
Detail **B**

unidades en mm / units: mm

Dimensiones de la tuerca / Nut dimensions										Referencia Type
D	D ₁	D ₂	X	Y	L	G	Z	C	F	
35	48	58	12	34	46	M6	5,5	5	12	RBS-2005
40	52	64	12	34	46	M6	5.5	5	12	RBS-2505
48	60	72	14	64	78				15	RBS-2510
48	60	72	12	39	51	M6	5.5	5	12	RBS-3205
54	66	78	16	64	80				6,5	15
56	70	82	14	44	58	M6	9	6	12	RBS-4005
62	76	94	18	75	93				7	15
70	88	108	15	44	59	M8x1	11	6,5	12	RBS-5005
72	90	110	18	85	103				7	15
85	105	125	22	85	107	M8x1	11	9	15	RBS-6310

- Standard thread RH only. Left-hand thread on request.
- R_{s1} = Rigidity of the ball screw shaft with one end fixed and one end free, per unit length of one metre. For two-end fixed systems, multiply by 4.
- R_{nu} = Rigidity of the nut for a working load equal to 30% of the dynamic load rating and for a tolerance grade of IT5.

Husillos a bolas rectificadas

Ground Ball Screws

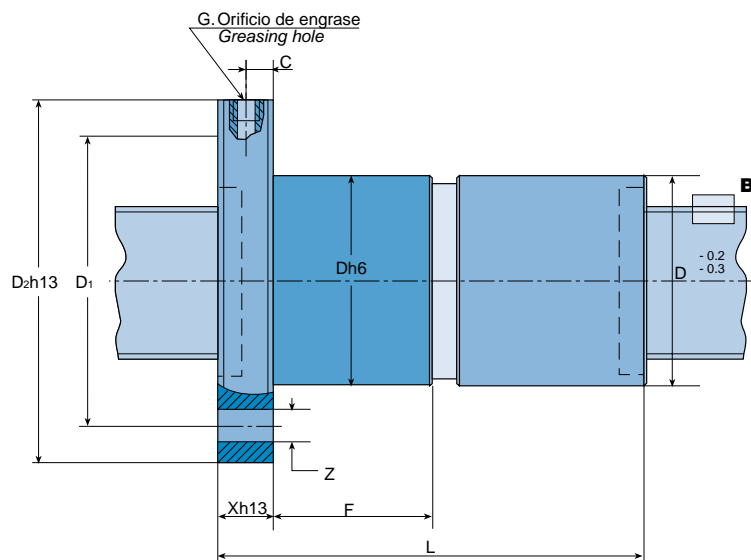

TUERCA DOBLE CON BRIDA

Tipo : UDBS

DOUBLE NUT WITH FLANGE

Type: UDBS

Referencia Type	Diámetro Diameter (d ₀)	Paso Lead (Ph)	Diam. bolas Ball diameter (Dw)	Circuitos Circuits (i)	D _{pw}	d ₂	Capacidad de carga Load rating		Rigidez / Rigidity		Dimensiones			
							C ₀ (N)	C _A (N)	R _{s1} (N/μm-m)	R _{nu} (N/μm)	D	D ₁	D ₂	X
UDBS-2505	25	5	3,5	3	26	22,5	31402	12205	91,3	297,2	40	52	64	12
UDBS-3205	32	5	3,5	4	33	29,5	55131	17791	153,7	477,5	48	60	72	12
UDBS-3210		10	6,35	3	34,1	27,75	65122	27753	144,6	299,3	54	66	78	16
UDBS-4005	40	5	3,5	5	41	37,5	88245	24062	244,7	695,1	56	70	82	14
UDBS-4010		10	6,35	4	42,1	35,75	115945	41641	233,3	495,1	62	76	94	18
UDBS-5010	50	10	7,144	5	52,1	44,96	206575	66239	365,0	710,9	72	90	110	18
UDBS-6310	63	10	7,144	5	65,1	57,96	275618	76390	594,6	872,3	85	105	125	22

• Standard unicamente rosca derecha. Rosca izquierda bajo consulta.

• R_{s1}= Rigidez del eje del husillo a bolas en el caso de un extremo fijo y otro libre por 1m de longitud. Para el caso de los dos extremos fijos multiplicar por 4.

• R_{nu}=Rigidez de la tuerca con una precarga del 6% de la capacidad de carga dinámica y una calidad IT5.

STOCK

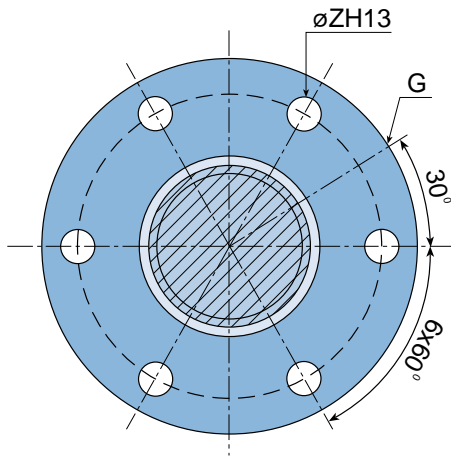

Paso
Lead

Diámetro Diameter	5	10	20	40
16				
20				
25	UDBS			
32	UDBS	UDBS		
40	UDBS	UDBS		
50		UDBS		
63		UDBS		

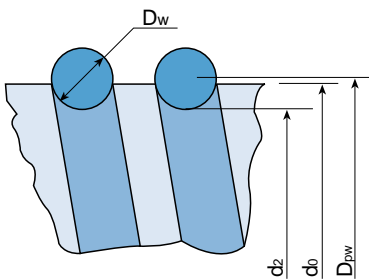

Detalle **B**
Detail **B**

unidades en mm / units: mm

de la tuerca / Nut dimensions						Referencia Type
Y	L	G	Z	C	F	
27	78	M6	5,5	6	27	UDBS-2505
33	89	M6	5,5	6	33	UDBS-3205
53	138			8	53	UDBS-3210
38	101	M6	9	7	38	UDBS-4005
64	162			9	64	UDBS-4010
75	183	M8x1	11	9	75	UDBS-5010
75	187	M8x1	11	11	75	UDBS-6310

- Standard thread RH only. Left-hand thread on request.
- R_{s1} = Rigidity of the ball screw shaft with one end fixed and one end free, per unit length of one metre. For two-end fixed systems, multiply by 4.
- R_{nu} = R_{nu} : Rigidity of the nut preloaded to 6% of the dynamic load rating and for a tolerance grade of IT5.

Husillos a bolas laminados y rectificados

Rolled and Ground Ball Screws

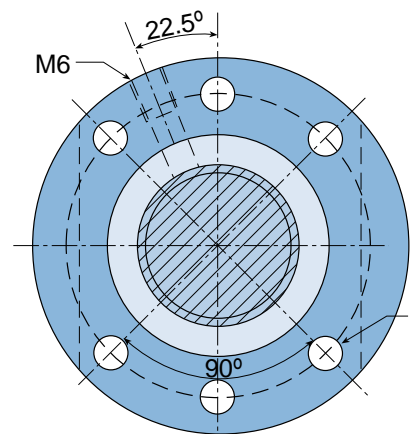
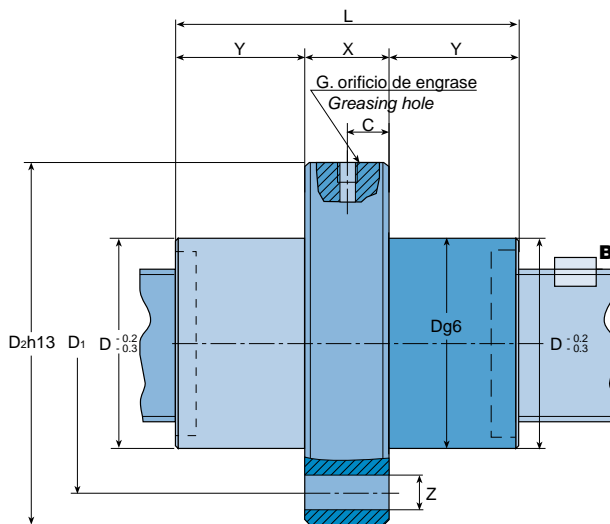

1

TUERCA SIMPLE CON BRIDA CENTRAL

Tipo : BSL

SINGLE NUT WITH CENTRAL FLANGE

Type: BSL

Referencia Type	Diámetro Diameter (d ₀)	Paso Lead (Ph)	Diam. bolas Ball diameter (Dw)	Circuitos Circuits (i)	D _{pw}	d ₂	Laminados / Rolled B.S.			Rectificados / Ground B.S.				
							C ₀ (N)	C _A (N)	Juego axial Backlash	R _{s1} (N/μm-m)	R _{nu} (N/μm)	C ₀ (N)	C _A (N)	Juego axial Backlash
BSL-2020	20	20	3,5	2	21	17,5	16163	6794	0,05	56,6	161,8	17959	7549	0,03
BSL-2520	25	20	3,5	2	26	22,5	21230	8470	0,05	91,3	208,0	23589	9411	0,03
BSL-2525		25		2			20900	8426		91,3	206,8	23222	9362	
BSL-3220	32	20	3,969	3	33,3	29,331	46431	15881	0,05	153,3	389,5	51590	17645	0,03
BSL-3232		32		2			30543	11205		153,3	259,5	33937	12450	
BSL-4020	40	20	6,35	3	40,1	33,75	90435	32612	0,05	209,1	462,5	100483	36235	0,03
BSL-4040		40		2			56104	22195		209,1	302,9	62338	24661	
BSL-5020	50	20	7,144	5	50	42,856	217622	6690	0,05	333,2	928,3	241802	7433	0,03
BSL-5050		50		2			82829	29829		333,2	373,8	92032	33143	
BSL-6320	63	20	7,144	5	65	57,856	280126	74672	0,05	592,6	1156,9	311251	82969	0,03

• Standard unicamente rosca derecha. Rosca izquierda bajo consulta.

• R_{s1}= Rigidez del eje del husillo a bolas en el caso de un extremo fijo y otro libre por 1m de longitud. Para el caso de los dos extremos fijos multiplicar por 4.

• R_{nu}= Rigidez de la tuerca para una carga de servicio media del 30% de la capacidad de carga dinámica y una calidad IT5.

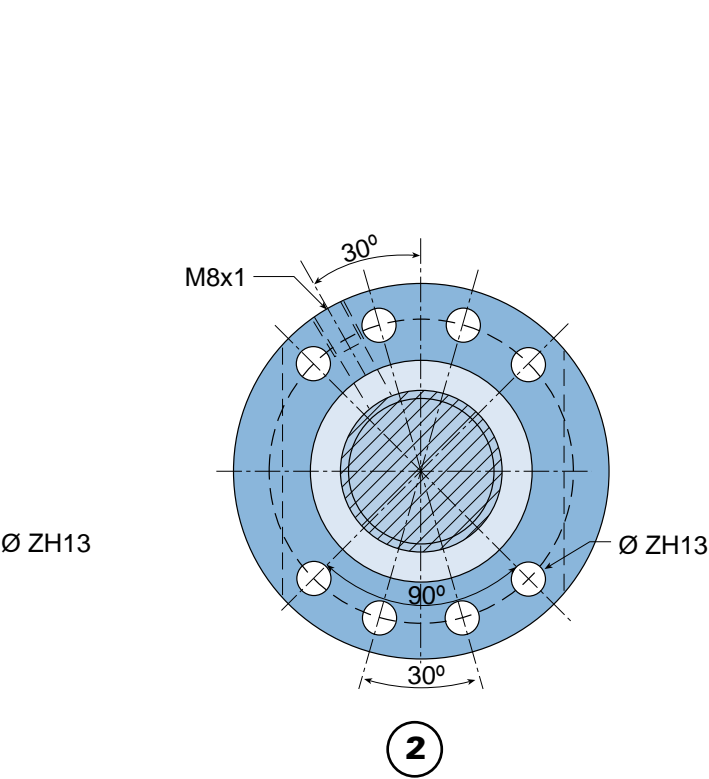

Diámetro Diameter	Paso Lead				
	20	25	32	40	50
16					
20	BSL				
25	BSL	BSL			
32	BSL		BSL		
40	BSL			BSL	
50	BSL				BSL
63	BSL				

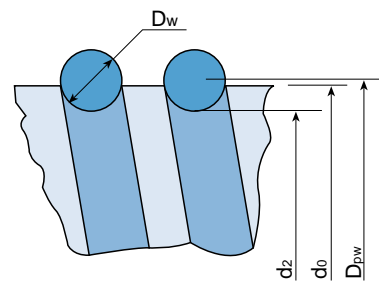

Detalle B
Detail B

unidades en mm / units: mm

Dimensiones de la tuerca / Nut dimensions											Referencia Type
D	D ₁	D ₂	X	Y	L	L ₈	L ₉	Tipo/Type	Z	C	
36	47	58	20	24	68	44	51	①	6,6	10	BSL-2020
40	51	62	20	24,5	69	48	55	①	6,6	10	BSL-2520
			25	26,5	78					12,5	BSL-2525
50	65	80	20	39,5	99	62	71	①	9	10	BSL-3220
				40,5	101						BSL-3232
63	78	93	30	36	102	70	81,5	②	9	15	BSL-4020
				45	120						BSL-4040
75	93	110	30	56,5	143	85	97,5	②	11	15	BSL-5020
				54,5	139						BSL-5050
95	115	135	30	57	144	100	117,5	②	13,5	15	BSL-6320

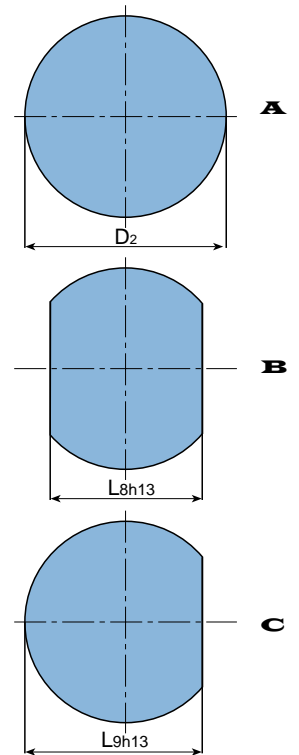

- Standard thread RH only. Left-hand thread on request.
- R_{s1} = Rigidity of the ball screw shaft with one end fixed and one end free, per unit length of one metre. For two-end fixed systems, multiply by 4.
- R_{nu} = Rigidity of the nut for a working load equal to 30% of the dynamic load rating and for a tolerance grade of IT5.

Husillos a bolas laminados y rectificados

Rolled and Ground Ball Screws

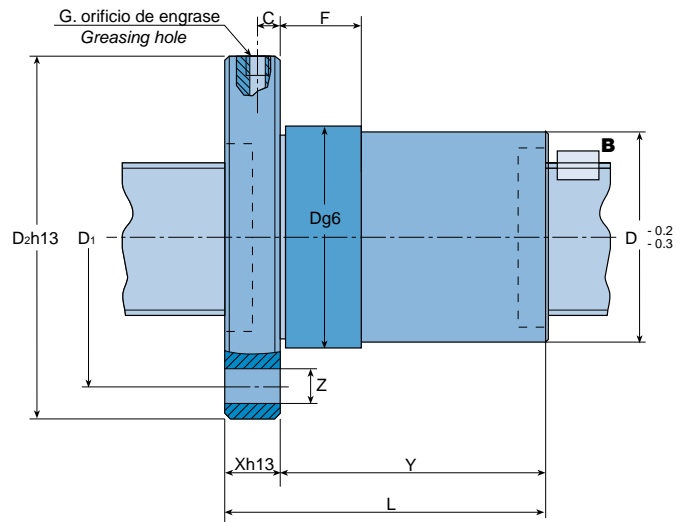

TUERCA SIMPLE CON BRIDA

Tipo : BS

SINGLE NUT WITH FLANGE

Type: BS

Referencia Type	Diámetro Diameter (d_0)	Paso Lead (Ph)	Diam. bolas Ball diameter (D_w)	D_{pw}	d_2	Circuitos Circuits (i)	Laminados / Rolled B.S.			Rectificados / Ground B.S.				
							C_0 (N)	C_A (N)	Juego axial Backlash	R_{s1} (N/μm-m)	R_{nu} (N/μm)	C_0 (N)	C_A (N)	Juego axial Backlash
BS-1204-2	12	4	2,381	12,66	10,279	2	5032	2849	0,05	19,9	82,5	5591	3165	0,03
BS-1204-3						3	7548	4037			121,6	8387	4485	
BS-1204-4						4	10065	5170			160,0	11183	5744	
BS-1205-2	12	5	2,381	12,66	10,279	2	5018	2846	0,05	19,9	83,2	5576	3162	0,03
BS-1205-3						3	7528	4033			122,5	8364	4481	
BS-1604-2	16	4	2,381	16,66	14,279	2	7794	3641	0,05	37,0	112,0	8660	4045	0,03
BS-1604-3						3	11690	5159			165,1	12989	5732	
BS-1604-4						4	15587	6607			217,4	17319	7341	
KBS-1605	16	5	3,5	17	13,5	2	10881	5759	0,05	34,8	116,3	12090	6399	0,03
BS-1605-3						3	16322	8162			171,4	18135	9069	
BS-1605-4						4	21762	10454			225,6	24180	11615	
BS-1610-2	16	10	3,5	17	13,5	2	10742	5735	0,05	34,8	119,2	11935	6372	0,03
BS-1610-3						3	16113	8127			175,6	17903	9030	
BS-1610-4						4	21484	10409			231,1	23871	11565	
BS-2004-2	20	4	2,381	20,66	18,279	2	10096	4128	0,05	59,4	142,4	11218	4587	0,03
BS-2004-3						3	15144	5851			210,0	16827	6501	
BS-2004-4						4	20192	7493			276,6	22436	8326	
BS-2005-2	20	5	3,5	21	17,5	2	13869	6578	0,05	56,6	141,9	15410	7309	0,03
KBS-2005						3	20804	9323			209,1	23116	10359	
BS-2005-4						4	27739	11940			275,4	30821	13267	
BS-2010-2	20	10	3,5	21	17,5	2	14734	6869	0,05	56,6	148,6	16371	7632	0,03
BS-2010-3						3	22101	9734			218,9	24557	10816	
BS-2010-4						4	29469	12467			288,2	32743	13852	
BS-2020-2	20	20	3,5	21	17,5	2	16163	7385	0,05	56,6	165,8	17959	8206	0,03

• Standard únicamente rosca derecha. Rosca izquierda bajo consulta.

• R_{s1} = Rigidez del eje del husillo a bolas en el caso de un extremo fijo y otro libre por 1m de longitud. Para el caso de los dos extremos fijos multiplicar por 4.

• R_{nu} = Rigidez de la tuerca para una carga de servicio media del 30% de la capacidad de carga dinámica y una calidad IT5.

Paso
Lead

Diámetro Diameter	4	5	6	8	10	12	16	20	25	32	40
12											
16											
20											
25											
32											
40											

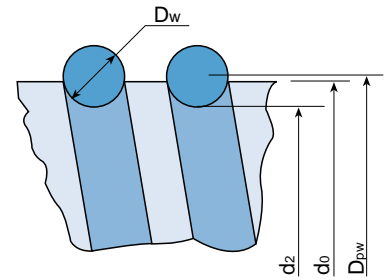
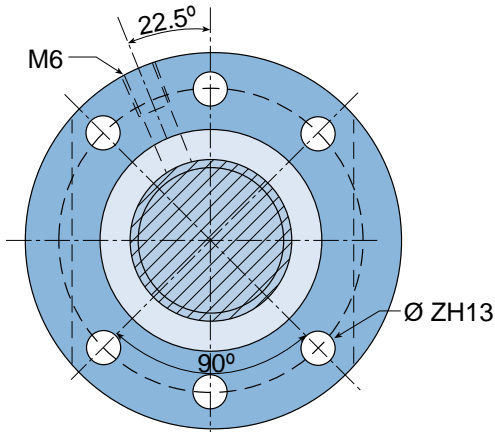

unidades en mm / units: mm

Dimensiones de la tuerca / Nut dimensions											Referencia Type
D	D ₁	D ₂	X	Y	L	L ₈	L ₉	Z	C	F	
24	32	40	10	24	34	31	35,5	5,5	5	10	BS-1204-2
				29	39						BS-1204-3
				33	43						BS-1204-4
24	32	40	10	28	38	31	35,5	5,5	5	10	BS-1205-2
				33	43						BS-1205-3
28	38	48	10	24	34	40	44	5,5	5	10	BS-1604-2
				29	39						BS-1604-3
				33	43						BS-1604-4
28	38	48	10	28	38	40	44	5,5	5	10	KBS-1605
				33	43						BS-1605-3
				38	48						BS-1605-4
28	38	48	10	43	53	40	44	5,5	5	16	BS-1610-2
				57	67						BS-1610-3
				67	77						BS-1610-4
36	47	58	10	24	34	44	51	6,6	5	10	BS-2004-2
				29	39						BS-2004-3
				33	43						BS-2004-4
36	47	58	10	28	38	44	51	6,6	5	10	BS-2005-2
				33	43						KBS-2005
				38	48						BS-2005-4
36	47	58	10	43	53	44	51	6,6	5	16	BS-2010-2
				57	67						BS-2010-3
				67	77						BS-2010-4
36	47	58	10	58	68	44	51	6,6	5	25	BS-2020-2

Detalle **B**
Detail **B**

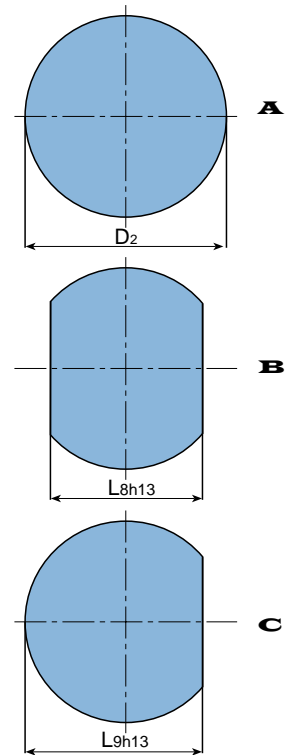

KBS Tuerca de STOCK con brida tipo **B**
STOCK nut. Flange type **B**

- Standard thread RH only. Left-hand thread on request.
- R_{s1} = Rigidity of the ball screw shaft with one end fixed and one end free, per unit length of one metre. For two-end fixed systems, multiply by 4.
- R_{nu} = Rigidity of the nut for a working load equal to 30% of the dynamic load rating and for a tolerance grade of IT5.

Husillos a bolas laminados y rectificados

Rolled and Ground Ball Screws



Korta

TUERCA SIMPLE CON BRIDA
Tipo : BS
SINGLE NUT WITH FLANGE
Type: BS

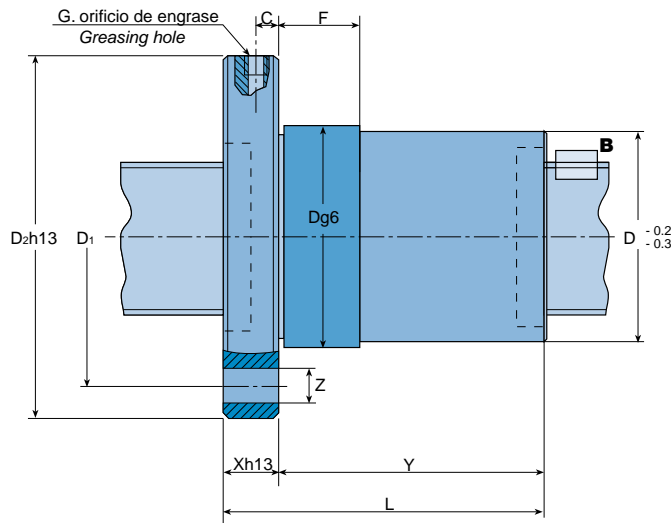

Referencia Type	Diámetro Diameter (d ₀)	Paso Lead (Ph)	Diam. bolas Ball diameter (D _w)	D _{pw}	d ₂	Circuitos Circuits (i)	Laminados / Rolled B.S.			Rectificados / Ground B.S.				
							C ₀ (N)	C _A (N)	Juego axial Backlash	R _{s1} (N/μm-m)	R _{nu} (N/μm)	C ₀ (N)	C _A (N)	Juego axial Backlash
BS-2504-2	25	4	2,381	25,66	23,279	2	12858	4601	0,05	94,8	167,5	14287	5112	0,03
BS-2504-3						3	19287	6520			247,2	21430	7244	
BS-2504-4						4	25717	8350			325,7	28574	9278	
BS-2505-2	25	5	3,5	26	22,5	2	18842	7751	0,05	91,3	177,1	20935	8612	0,03
KBS-2505						3	28262	10985			261,1	31402	12205	
BS-2505-4						4	37683	14069			344,0	41870	15632	
BS-2506-2	25	6	3,969	26,3	22,331	2	20388	8863	0,05	91,0	175,1	22653	9848	0,03
BS-2506-3						3	30582	12561			258,1	33980	13957	
BS-2506-4						4	40776	16087			340,0	45307	17874	
BS-2510-2	25	10	4,76	26,6	21,84	2	23720	10994	0,05	89,0	179,7	26355	12216	0,03
KBS-2510						3	35579	15582			264,7	39532	17313	
BS-2510-4						4	47439	19956			348,6	52710	22173	
KBS-2520	25	20	3,5	26	22,5	2	21230	8470	0,05	91,3	208,0	23589	9411	0,03
BS-2520-3						3	31845	12003			312,5	35383	13337	
BS-2525-2	25	25	3,5	26	22,5	2	20900	8426	0,05	91,3	206,8	23222	9362	0,03
BS-3204-3	32	4	2,381	32,66	30,279	3	26188	7501	0,05	158,2	306,9	29098	8334	0,03
BS-3204-4						4	34917	9607			404,6	38797	10674	
BS-3204-5						5	43646	11639			501,2	48496	12932	
BS-3205-3	32	5	3,5	33	29,5	3	37213	12503	0,05	153,7	319,2	41348	13892	0,03
KBS-3205						4	49618	16012			420,6	55131	17791	
BS-3205-5						5	62022	19400			521,0	68913	21555	
BS-3206-3	32	6	3,969	33,3	29,331	3	42092	14794	0,05	153,3	328,6	46769	16438	0,03
BS-3206-4						4	56122	18947			433,0	62358	21052	
BS-3206-5						5	70153	22955			536,3	77948	25506	
BS-3208-3	32	8	4,762	33,6	28,838	3	49514	18631	0,05	150,7	337,7	55016	20701	0,03
BS-3208-4						4	66020	23861			444,8	73355	26512	
BS-3208-5						5	82525	28909			550,8	91694	32121	
KBS-3210	32	10	6,35	34,1	27,75	3	58610	24978	0,05	144,6	317,6	65122	27753	0,03
BS-3210-4						4	78146	31989			418,2	86829	35543	
BS-3210-5						5	97683	38757			517,8	108537	43063	
BS-3220-2	32	20	3,969	33,3	29,331	2	30117	11003	0,05	153,3	258,3	33463	12225	0,03
KBS-3220						3	46431	15881			389,5	51590	17645	
KBS-3232	32	32	3,969	33,3	29,331	2	30543	11205	0,05	153,3	259,4	33937	12450	0,03

- Standard únicamente rosca derecha. Rosca izquierda bajo consulta
- R_{s1}= Rigidez del eje del husillo a bolas en el caso de un extremo fijo y otro libre por 1m de longitud. Para el caso de los dos extremos fijos multiplicar por 4.
- R_{nu}= Rigidez de la tuerca para una carga de servicio media del 30% de la capacidad de carga dinámica y una calidad IT5.

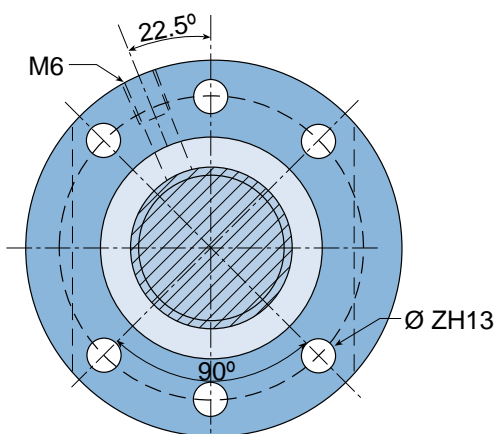

Diámetro Diameter	Paso Lead										
	4	5	6	8	10	12	16	20	25	32	40
12											
16											
20											
25											
32											
40											

unidades en mm / units: mm

Dimensiones de la tuerca / Nut dimensions											Referencia Type
D	D ₁	D ₂	X	Y	L	L ₈	L ₉	Z	C	F	
40	51	62	10	24	34	48	55	6,6	5	10	BS-2504-2
				29	39						BS-2504-3
				33	43						BS-2504-4
40	51	62	10	28	38	48	55	6,6	5	10	BS-2505-2
				33	43						KBS-2505
				38	48						BS-2505-4
40	51	62	10	32	42	48	55	6,6	5	10	BS-2506-2
				41	51						BS-2506-3
				47	57						BS-2506-4
40	51	62	10	44	54	48	55	6,6	5	16	BS-2510-2
				55	65						KBS-2510
				67	77						BS-2510-4
40	51	62	10	59	69	48	55	6,6	5	25	KBS-2520
				79	89						BS-2520-3
40	51	62	10	68	78	48	55	6,6	5	30	BS-2525-2
50	65	80	12	29	41	62	71	9	6	10	BS-3204-3
				33	45						BS-3204-4
				37	49						BS-3204-5
50	65	80	12	33	45	62	71	9	6	10	BS-3205-3
				38	50						KBS-3205
				43	55						BS-3205-5
50	65	80	12	41	53	62	71	9	6	10	BS-3206-3
				47	59						BS-3206-4
				54	66						BS-3206-5
50	65	80	12	49	61	62	71	9	6	16	BS-3208-3
				57	69						BS-3208-4
				65	77						BS-3208-5
50	65	80	12	63	75	62	71	9	6	16	KBS-3210
				74	86						BS-3210-4
				84	96						BS-3210-5
50	65	80	12	67	79	62	71	9	6	25	BS-3220-2
				87	99						KBS-3220
50	65	80	12	89	101	62	71	9	6	40	KBS-3232

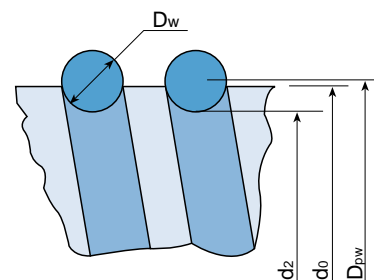

Detalle B
Detail B

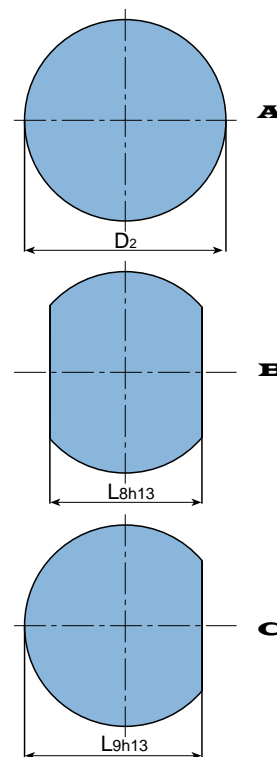

KBS Tuerca de STOCK con brida tipo B
STOCK nut. Flange type B

- Standard thread:RH only. Left-hand thread on request.
- R_{S1} = Rigidity of the ball screw shaft with one end fixed and one end free, per unit length of one metre. For two-end fixed systems, multiply by 4.
- R_{nu} = Rigidity of the nut for a working load equal to 30% of the dynamic load rating and for a tolerance grade of IT5.

Husillos a bolas laminados y rectificados

Rolled and Ground Ball Screws

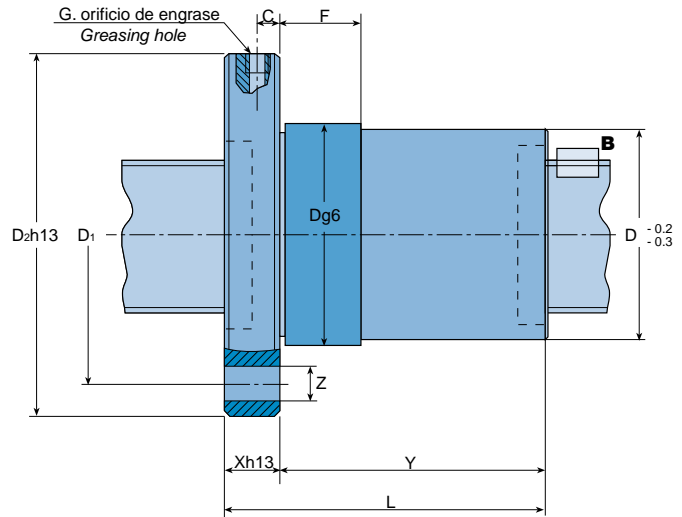

TUERCA SIMPLE CON BRIDA

Tipo : BS

SINGLE NUT WITH FLANGE

Type: BS

Referencia Type	Diámetro Diameter (d ₀)	Paso Lead (Ph)	Diam. bolas Ball diameter (D _w)	D _{pw}	d ₂	Circuitos Circuits (i)	Laminados / Rolled B.S.			Rectificados / Ground B.S.				
							C ₀ (N)	C _A (N)	Juego axial Backlash	R _{s1} (N/μm·m)	R _{nu} (N/μm)	C ₀ (N)	C _A (N)	Juego axial Backlash
BS-4005-3	40	5	3,5	41	37,5	3	47652	13957	0,05	244,7	382,5	52947	15508	0,03
BS-4005-4						4	63536	17875			504,2	70596	19861	
KBS-4005						5	79421	21656			624,6	88245	24062	
BS-4005-6						6	95305	25332			744,1	105894	28147	
BS-4006-3	40	6	3,969	41,3	37,331	3	53602	16503	0,05	244,3	393,9	59558	18337	0,03
BS-4006-4						4	71470	21137			519,1	79411	23485	
BS-4006-5						5	89337	25608			643,0	99263	28453	
BS-4006-6						6	107204	29955			765,9	119116	33283	
BS-4008-3	40	8	4,762	41,6	36,838	3	63331	20956	0,05	241,0	408,7	70368	23284	0,03
BS-4008-4						4	84443	26838			538,5	93825	29820	
BS-4008-5						5	105553	32515			666,8	117281	36128	
BS-4008-6						6	126663	38035			794,1	140737	42261	
BS-4010-3	40	10	6,35	42,1	35,75	3	78263	29263	0,05	233,3	401,5	86959	32514	0,03
KBS-4010						4	104351	37477			528,8	115945	41641	
BS-4010-5						5	130438	45405			654,7	144931	50450	
BS-4010-6						6	156525	53113			779,6	173917	59014	
BS-4012-3	40	12	6,35	42,1	33,75	3	78165	29250	0,05	233,3	407,2	86850	32500	0,03
BS-4012-4						4	104220	37461			536,2	115800	41623	
BS-4012-5						5	130275	45386			663,8	144750	50429	
BS-4020-2	40	20	6,35	40,1	33,75	2	58136	22460	0,05	209,1	304,0	64596	24955	0,03
KBS-4020						3	90435	32612			462,5	100483	36235	
BS-4020-4						4	122733	42261			618,5	136370	46957	
KBS-4040						2	56104	22195			0,05	209,1	302,9	

• Standard únicamente rosca derecha. Rosca izquierda bajo consulta.

• R_{s1}= Rigidez del eje del husillo a bolas en el caso de un extremo fijo y otro libre por 1m de longitud. Para el caso de los dos extremos fijos multiplicar por 4.

• R_{nu}= Rigidez de la tuerca para una carga de servicio media del 30% de la capacidad de carga dinámica y una calidad IT5.

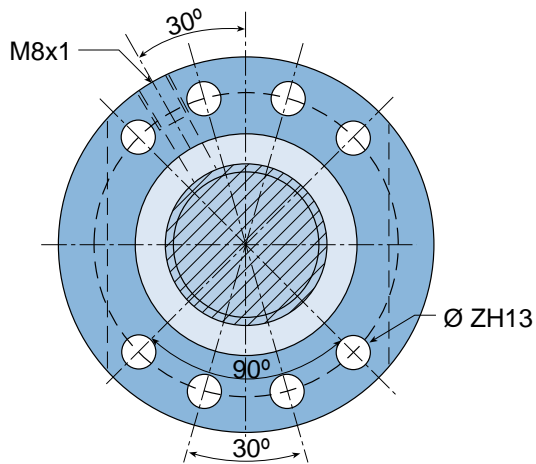

Diámetro Diameter	Paso Lead										
	4	5	6	8	10	12	16	20	25	32	40
12											
16											
20											
25											
32											
40											

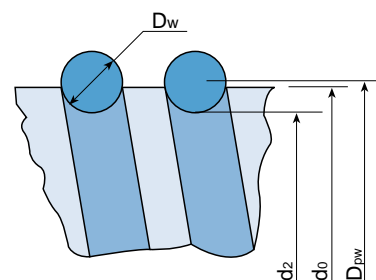

unidades en mm / units: mm

Dimensiones de la tuerca / Nut dimensions											Referencia Type
D	D ₁	D ₂	X	Y	L	L ₈	L ₉	Z	C	F	
63	78	93	14	33	47	70	81,5	9	7	10	BS-4005-3
				38	52						BS-4005-4
				43	57						KBS-4005
				50	64						BS-4005-6
63	78	93	14	41	55	70	81,5	9	7	10	BS-4006-3
				47	61						BS-4006-4
				54	68						BS-4006-5
				61	75						BS-4006-6
63	78	93	14	49	63	70	81,5	9	7	16	BS-4008-3
				57	71						BS-4008-4
				65	79						BS-4008-5
				74	88						BS-4008-6
63	78	93	14	63	77	70	81,5	9	7	16	BS-4010-3
				74	88						KBS-4010
				84	98						BS-4010-5
				95	109						BS-4010-6
63	78	93	14	70	84	70	81,5	9	7	20	BS-4012-3
				83	97						BS-4012-4
				95	109						BS-4012-5
				68	82						BS-4020-2
63	78	93	14	88	102	70	81,5	9	7	25	KBS-4020
				108	122						BS-4020-4
				106	120						KBS-4040

Detalle B
Detail B

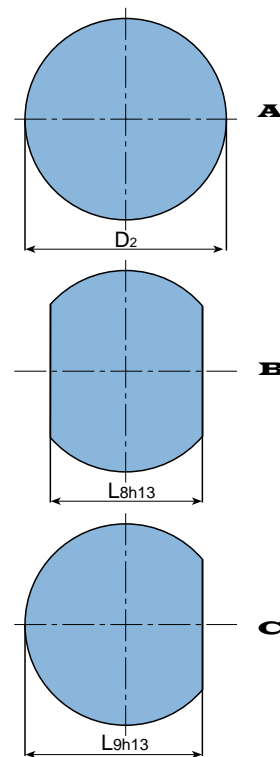

KBS Tuerca de STOCK con brida tipo B
STOCK nut. Flange type B

- Standard thread RH only. Left-hand thread on request.
- R_{s1} = Rigidity of the ball screw shaft with one end fixed and one end free, per unit length of one metre. For two-end fixed systems, multiply by 4.
- R_{nu} = Rigidity of the nut for a working load equal to 30% of the dynamic load rating and for a tolerance grade of IT5.

Husillos a bolas laminados y rectificados

Rolled and Ground Ball Screws



Korta

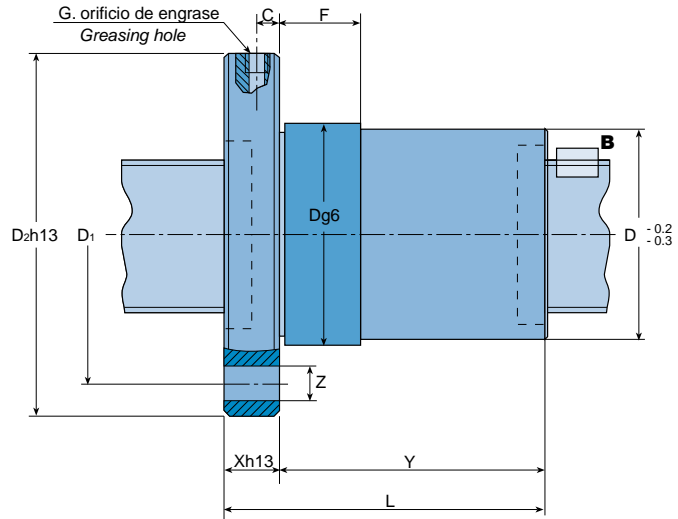

TUERCA SIMPLE CON BRIDA

Tipo : BS

SINGLE NUT WITH FLANGE

Type: BS

Referencia Type	Diámetro Diameter (d ₀)	Paso Lead (Ph)	Diam. bolas Ball diameter (Dw)	D _{pw}	d ₂	Circuitos Circuits (i)	Laminados / Rolled B.S.			Rectificados / Ground B.S.				
							C ₀ (N)	C _A (N)	Juego axial Backlash	R _{s1} (N/μm-m)	R _{nu} (N/μm)	C ₀ (N)	C _A (N)	Juego axial Backlash
BS-5005-3	50	5	3,5	51	47,5	3	61071	15529	0,05	388,3	447,6	67857	17254	0,03
BS-5005-4						4	81428	19888			590,3	90475	22098	
KBS-5005						5	101785	24095			731,7	113094	26772	
BS-5005-6						6	122142	28185			871,9	135713	31317	
BS-5006-3	50	6	3,969	51,3	47,331	3	68943	18446	0,05	387,8	465,0	76603	20495	0,03
BS-5006-4						4	91924	23623			613,1	102138	26248	
BS-5006-5						5	114905	28621			759,7	127672	31801	
BS-5006-6						6	137886	33480			905,1	153207	37200	
BS-5008-3	50	8	4,762	51,6	46,838	3	82661	23739	0,05	383,6	492,3	91845	26377	0,03
BS-5008-4						4	110214	30404			648,9	122460	33782	
BS-5008-5						5	137768	36835			803,8	153075	40928	
BS-5008-6						6	165321	43088			957,4	183690	47876	
BS-5010-3	50	10	7,144	52	44,856	3	111550	38436	0,05	363,5	480,9	123944	42707	0,03
BS-5010-4						4	148733	49225			633,7	165259	54694	
KBS-5010						5	185917	59639			784,8	206574	66265	
BS-5010-6						6	223100	69763			934,7	247889	77514	
BS-5012-3	50	12	7,938	52,2	44,262	3	122324	43801	0,05	357,9	488,2	135915	48668	0,03
BS-5012-4						4	163097	56095			643,1	181219	62328	
BS-5012-5						5	203872	67963			796,4	226524	75514	
BS-5016-2	50	16	7,144	50	42,856	2	74151	27095	0,05	333,2	340,3	82390	30105	0,03
BS-5016-3						3	111227	38399			501,6	123585	42665	
BS-5016-4						4	148302	49177			660,6	164780	54641	
BS-5016-5						5	185378	59581			817,8	205975	66201	
BS-5020-3	50	20	7,144	50	42,856	3	127288	42389	0,05	333,2	557,1	141431	47099	0,03
BS-5020-4						4	172454	54870			743,8	191616	60967	
KBS-5020						5	217622	66900			928,3	241802	74333	
BS-5040-2	50	40	7,144	50	42,856	2	80224	29037	0,05	333,2	372,3	89138	32263	0,03
BS-5050-2	50	50	7,144	50	42,856	2	82829	29829	0,05	333,2	373,8	92032	33143	0,03

• Standard unicamente rosca derecha. Rosca izquierda bajo consulta.

• R_{s1}= Rigidez del eje del husillo a bolas en el caso de un extremo fijo y otro libre por 1m de longitud. Para el caso de los dos extremos fijos multiplicar por 4.

• R_{nu}= Rigidez de la tuerca para una carga de servicio media del 30% de la capacidad de carga dinámica y una calidad IT5.

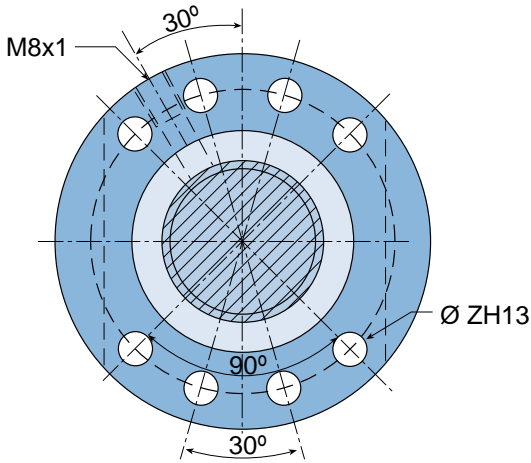

Diámetro Diameter	Paso Lead											
	4	5	6	8	10	12	16	20	25	32	40	50
50												
63												
80												
100												
120												

unidades en mm / units: mm

Dimensiones de la tuerca / Nut dimensions											Referencia Type
D	D ₁	D ₂	X	Y	L	L ₈	L ₉	Z	C	F	
75	93	110	16	33	49	85	97,5	11	8	10	BS-5005-3
				38	54						BS-5005-4
				43	59						KBS-5005
				50	66						BS-5005-6
75	93	110	16	41	57	85	97,5	11	8	10	BS-5006-3
				47	63						BS-5006-4
				54	70						BS-5006-5
				61	77						BS-5006-6
75	93	110	16	49	65	85	97,5	11	8	16	BS-5008-3
				57	73						BS-5008-4
				65	81						BS-5008-5
				74	90						BS-5008-6
75	93	110	16	63	79	85	97,5	11	8	16	BS-5010-3
				74	90						BS-5010-4
				84	100						KBS-5010
				95	111						BS-5010-6
75	93	110	16	73	89	85	97,5	11	8	20	BS-5012-3
				86	102						BS-5012-4
				99	115						BS-5012-5
75	93	110	16	60	76	85	97,5	11	8	25	BS-5016-2
				76	92						BS-5016-3
				92	108						BS-5016-4
				108	124						BS-5016-5
75	93	110	16	87	103	85	97,5	11	8	25	BS-5020-3
				107	123						BS-5020-4
				127	143						KBS-5020
75	93	110	16	106	122	85	97,5	11	8	45	BS-5040-2
75	93	110	16	123	139	85	97,5	11	8	55	BS-5050-2

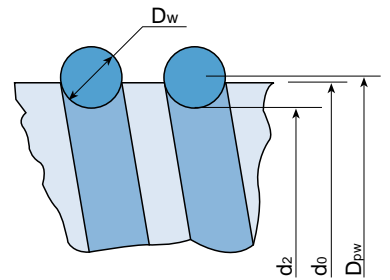

Detalle B
Detail B

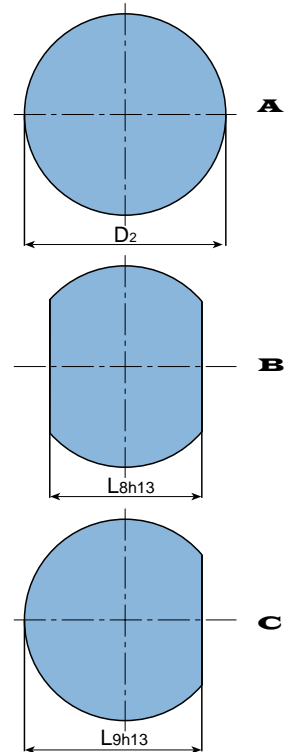

KBS Tuerca de STOCK con brida tipo B
STOCK nut. Flange type B

• Standard thread RH only. Left-hand thread on request.

• R_{s1}= Rigidity of the ball screw shaft with one end fixed and one end free, per unit length of one metre. For two-end fixed systems, multiply by 4.

• R_{nu}= Rigidity of the nut for a working load equal to 30% of the dynamic load rating and for a tolerance grade of IT5.

Husillos a bolas laminados y rectificados

Rolled and Ground Ball Screws



Korta

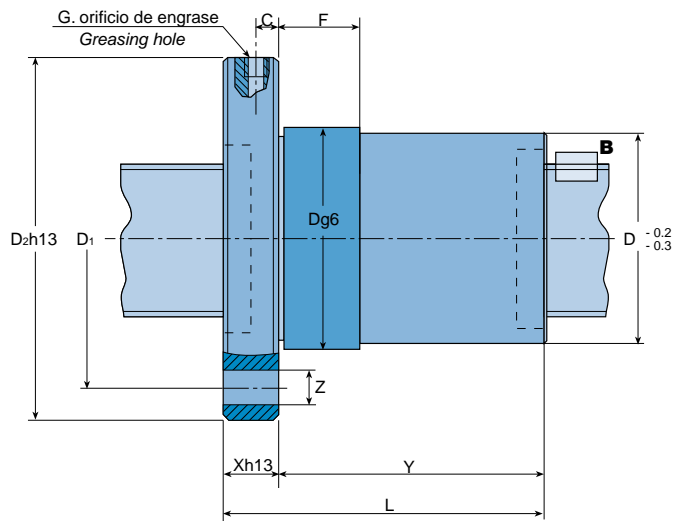

TUERCA SIMPLE CON BRIDA

Tipo : BS

SINGLE NUT WITH FLANGE

Type: BS

Referencia Type	Diámetro Diameter (d ₀)	Paso Lead (Ph)	Diam. bolas Ball diameter (D _w)	D _{pw}	d ₂	Circuitos Circuits (i)	Laminados / Rolled B.S.			Rectificados / Ground B.S.				
							C ₀ (N)	C _A (N)	Juego axial Backlash	R _{s1} (N/μm·m)	R _{nu} (N/μm)	C ₀ (N)	C _A (N)	Juego axial Backlash
BS-6305-3	63	5	3,5	64	60,5	3	78960	17295	0,05	624,2	519,1	87733	19217	0,03
BS-6305-4						4	105279	22150			685,0	116977	24611	
KBS-6305						5	131599	26836			849,4	146221	29818	
BS-6305-6						6	157919	31391			1012,6	175465	34879	
BS-6306-3	63	6	3,969	64,3	60,331	3	88116	20418	0,05	623,6	538,7	97907	22687	0,03
BS-6306-4						4	117488	26150			710,7	130542	29055	
BS-6306-5						5	146860	31681			881,0	163178	35201	
BS-6306-6						6	176232	37059			1050,0	195813	41177	
BS-6310-3	63	10	7,144	65	57,856	3	148833	44325	0,05	592,6	586,9	165370	49250	0,03
BS-6310-4						4	198445	56767			773,7	220494	63074	
KBS-6310						5	248055	68776			958,6	275617	76418	
BS-6310-6						6	297667	80451			1142,0	330741	89390	
BS-6312-3	63	12	7,938	65,2	57,262	3	160703	50181	0,05	585,5	592,5	178559	55757	0,03
BS-6312-4						4	214270	64266			780,9	238078	71407	
BS-6312-5						5	267838	77863			967,3	297598	86514	
BS-6312-6						6	321405	91080			1152,1	357117	101200	
BS-6316-3	63	16	7,144	65	57,856	3	165063	47521	0,05	592,6	644,2	183403	52801	0,03
BS-6316-4						4	222835	61366			857,0	247594	68184	
BS-6316-5						5	280607	74714			1067,4	311785	83016	
BS-6316-6						6	338378	87683			1275,9	375976	97426	
BS-6320-3	63	20	7,144	65	57,856	3	164780	47494	0,05	592,6	698,1	183089	52771	0,03
BS-6320-4						4	222453	61331			928,8	247170	68145	
KBS-6320						5	280126	74672			1156,9	311251	82969	
BS-6320-6						6	337799	87634			1382,9	375332	97371	
BS-6340-2	63	40	7,144	65	57,856	2	109674	33632	0,05	592,6	481,3	121860	37369	0,03
BS-6340-3						3	168574	48446			724,3	187304	53829	

• Standard únicamente rosca derecha. Rosca izquierda bajo consulta.

• R_{s1}= Rigidez del eje del husillo a bolas en el caso de un extremo fijo y otro libre por 1m de longitud. Para el caso de los dos extremos fijos multiplicar por 4.

• R_{nu}= Rigidez de la tuerca para una carga de servicio media del 30% de la capacidad de carga dinámica y una calidad IT5.

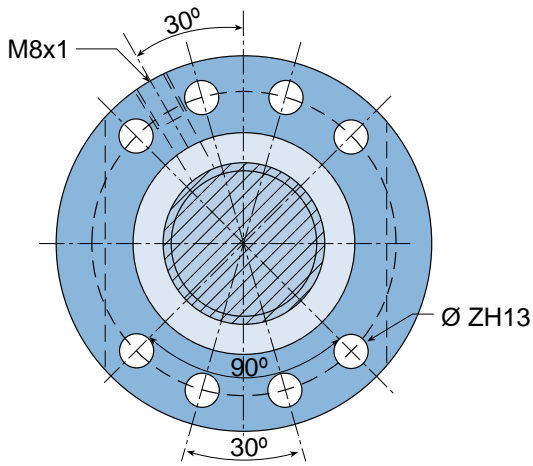

Diámetro Diameter	Paso Lead											
	4	5	6	8	10	12	16	20	25	32	40	64
50												
63												
80												
100												
120												

unidades en mm / units: mm

Dimensiones de la tuerca / Nut dimensions											Referencia Type
D	D ₁	D ₂	X	Y	L	L ₈	L ₉	Z	C	F	
90	108	125	18	33	51	95	110	11	9	10	BS-6305-3
				38	56						BS-6305-4
				43	61						KBS-6305
				50	68						BS-6305-6
90	108	125	18	41	59	95	110	11	9	10	BS-6306-3
				47	65						BS-6306-4
				54	72						BS-6306-5
90	108	125	18	61	79	95	110	11	9	10	BS-6306-6
				63	81						BS-6310-3
				74	92						BS-6310-4
90	108	125	18	84	102	95	110	11	9	16	KBS-6310
				95	113						BS-6310-6
				73	91						BS-6312-3
90	108	125	18	86	104	95	110	11	9	20	BS-6312-4
				99	117						BS-6312-5
				111	129						BS-6312-6
95	115	135	20	72	92	100	117,5	13,5	10	25	BS-6316-3
				88	108						BS-6316-4
				104	124						BS-6316-5
95	115	135	20	120	140	100	117,5	13,5	10	25	BS-6316-6
				84	104						BS-6320-3
				104	124						BS-6320-4
95	115	135	20	124	144	100	117,5	13,5	10	25	KBS-6320
				144	164						BS-6320-6
				103	123						BS-6340-2
95	115	135	20	143	163	100	117,5	13,5	10	45	BS-6340-3

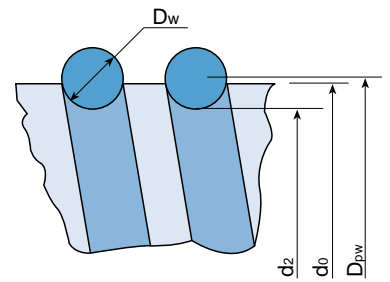

Detalle B
Detail B

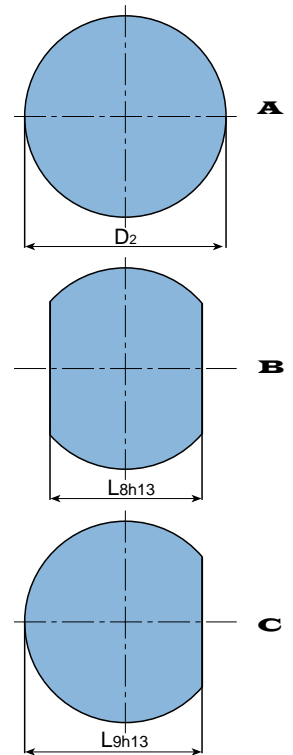

KBS Tuerca de STOCK con brida tipo B
STOCK nut. Flange type B

- Standard thread RH only. Left-hand thread on request.
- R_{S1} = Rigidity of the ball screw shaft with one end fixed and one end free, per unit length of one metre. For two-end fixed systems, multiply by 4.
- R_{nu} = Rigidity of the nut for a working load equal to 30% of the dynamic load rating and for a tolerance grade of IT5.

Husillos a bolas laminados y rectificados

Rolled and Ground Ball Screws

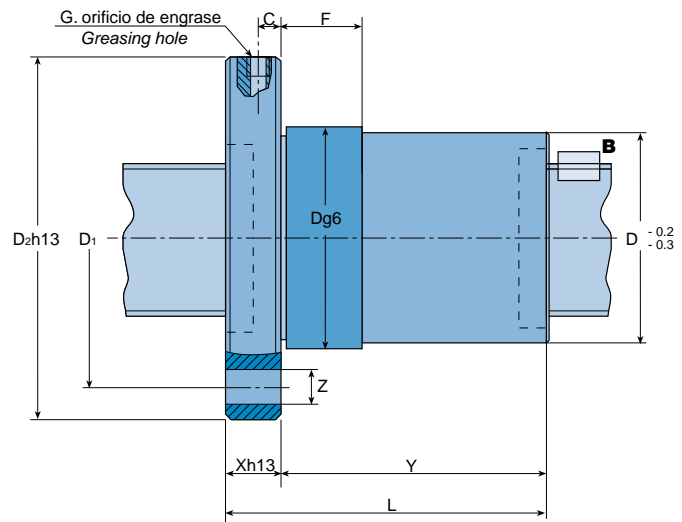

TUERCA SIMPLE CON BRIDA

Tipo : BS

SINGLE NUT WITH FLANGE

Type: BS

Referencia Type	Diámetro Diameter (d ₀)	Paso Lead (Ph)	Diam. bolas Ball diameter (D _w)	D _{pw}	d ₂	Circuitos Circuits (i)	Laminados / Rolled B.S.			Rectificados / Ground B.S.				
							C ₀ (N)	C _A (N)	Juego axial Backlash	R _{s1} (N/μm·m)	R _{nu} (N/μm)	C ₀ (N)	C _A (N)	Juego axial Backlash
BS-8010-4	80	10	7,144	82	74,856	4	264710	64910	0,06	976,4	900,4	294122	72122	0,06
BS-8010-5						5	330888	78642			1116,3	367653	87380	
BS-8010-6						6	397066	91992			1330,7	441184	102213	
BS-8012-4	80	12	7,938	82,2	74,262	4	285875	73690	0,06	967,3	918,3	317639	81878	0,06
BS-8012-5						5	357344	89279			1138,2	397049	99199	
BS-8012-6						6	428813	104435			1356,5	476459	116039	
BS-8016-4	80	16	9,525	82,6	73,075	4	323142	90896	0,06	949,1	996,5	359047	100996	0,06
BS-8016-5						5	403927	110126			1233,9	448808	122362	
BS-8016-6						6	484713	128820			1469,3	538570	143133	
BS-8020-3	80	20	9,525	82,6	73,075	3	282449	78628	0,06	949,1	873,9	313832	87364	0,06
BS-8020-4						4	381489	101569			1163,2	423877	112854	
BS-8020-5						5	480530	123686			1449,2	533922	137429	
BS-8020-6						6	579569	145173			1732,7	643966	161303	
BS-8040-2	80	40	9,525	82,6	73,075	2	181805	54356	0,06	949,1	603,6	202005	60395	0,06
BS-8040-3						3	279979	78398			909,3	311088	87109	
BS-8040-4						4	378154	101272			1210,1	420171	112524	

• Standard únicamente rosca derecha. Rosca izquierda bajo consulta.

• R_{s1}= Rigidez del eje del husillo a bolas en el caso de un extremo fijo y otro libre por 1m de longitud. Para el caso de los dos extremos fijos multiplicar por 4.

• R_{nu}= Rigidez de la tuerca para una carga de servicio media del 30% de la capacidad de carga dinámica y una calidad IT5.

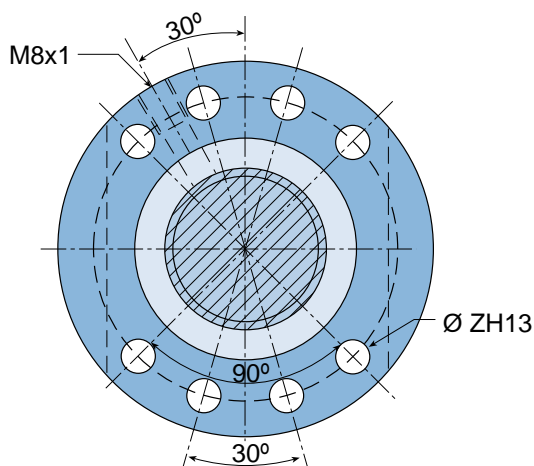

Diámetro Diameter	Paso Lead											
	4	5	6	8	10	12	16	20	25	32	40	64
50												
63												
80												
100												
120												

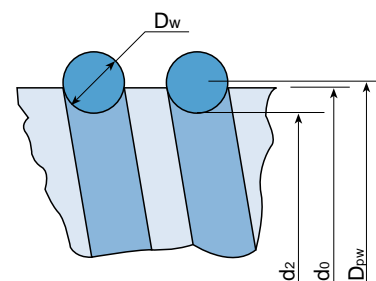

Detalle B
Detail B

unidades en mm / units: mm

Dimensiones de la tuerca / Nut dimensions											Referencia Type
D	D ₁	D ₂	X	Y	L	L ₈	L ₉	Z	C	F	
105	125	145	20	74	94	110	127,5	13,5	10	16	BS-8010-4
				84	104						BS-8010-5
				95	115						BS-8010-6
105	125	145	20	86	106	110	127,5	13,5	10	20	BS-8012-4
				99	119						BS-8012-5
				111	131						BS-8012-6
125	145	165	25	86	111	130	147,5	13,5	12,5	25	BS-8016-4
				102	127						BS-8016-5
				118	143						BS-8016-6
125	145	165	25	81	106	130	147,5	13,5	12,5	25	BS-8020-3
				101	126						BS-8020-4
				121	146						BS-8020-5
				141	166						BS-8020-6
125	145	165	25	101	126	130	147,5	13,5	12,5	45	BS-8040-2
				141	166						BS-8040-3
				181	206						BS-8040-4

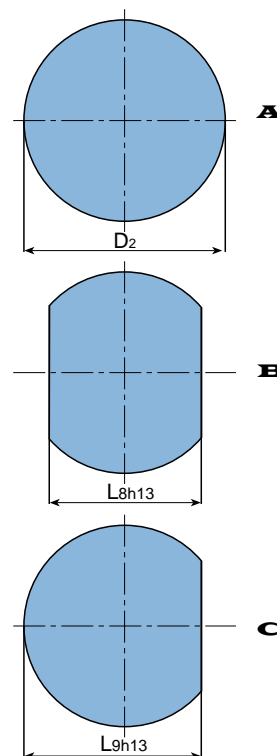

- Standard thread RH only. Left-hand thread on request.
- R_{S1} = Rigidity of the ball screw shaft with one end fixed and one end free, per unit length of one metre. For two-end fixed systems, multiply by 4.
- R_{nu} = Rigidity of the nut for a working load equal to 30% of the dynamic load rating and for a tolerance grade of IT5.

Husillos a bolas laminados y rectificados

Rolled and Ground Ball Screws



Korta

TUERCA SIMPLE CON BRIDA

Tipo : BS

SINGLE NUT WITH FLANGE

Type: BS

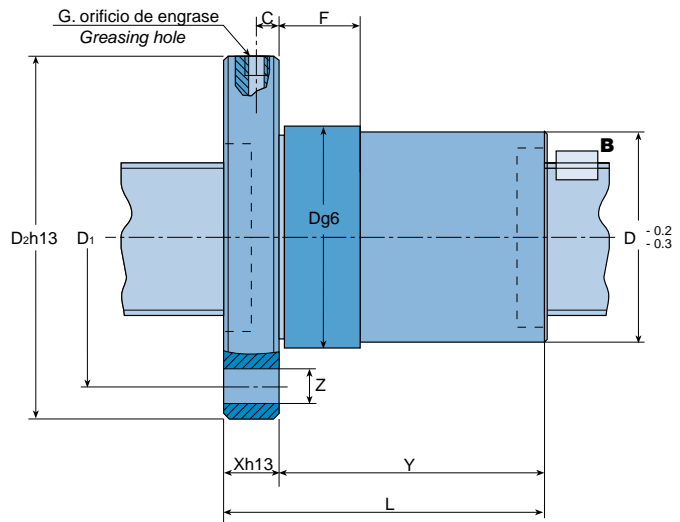

Referencia Type	Diámetro Diameter (d ₀)	Paso Lead (Ph)	Diam. bolas Ball diameter (D _w)	D _{pw}	d ₂	Circuitos Circuits (i)	Laminados / Rolled B.S.			Rectificados / Ground B.S.				
							C ₀ (N)	C _A (N)	Juego axial Backlash	R _{s1} (N/μm-m)	R _{nu} (N/μm)	C ₀ (N)	C _A (N)	Juego axial Backlash
BS-10010-4	100	10	7,144	102	94,856	4	330976	71061	0,06	1549,9	989,9	367751	78957	0,06
BS-10010-5						5	413720	86095			1228,2	459689	95661	
BS-10010-6						6	496463	100710			1464,8	551626	111900	
BS-10012-4	100	12	7,938	102,2	94,262	4	367694	82347	0,06	1538,4	1038,7	408549	91497	0,06
BS-10012-5						5	459617	99768			1288,4	510686	110853	
BS-10012-6						6	551541	116705			1536,3	612823	129672	
BS-10016-4	100	16	9,525	102,6	93,075	4	411546	101283	0,06	1515,5	1182,8	457273	112537	0,06
BS-10016-5						5	514433	122711			1465,0	571592	136345	
BS-10016-6						6	617319	143541			1744,9	685910	159490	
BS-10020-4	100	20	9,525	102,6	93,075	4	470013	110687	0,06	1515,5	1347,2	522237	122986	0,06
BS-10020-5						5	591188	134663			1676,7	656876	149625	
BS-10020-6						6	712364	157956			2003,4	791516	175507	
BS-10040-3	100	40	9,525	102,6	93,075	3	357801	87457	0,06	1515,5	1075,2	397557	97174	0,06
BS-10040-4						4	481937	112766			1428,0	535485	125296	
BS-10040-5						5	606072	137174			1776,7	673413	152416	
BS-12010-5	120	10	7,144	122	114,856	5	506881	93790	0,06	2255,4	1403,3	563201	104211	0,06
BS-12010-6						6	608257	109712			1674,0	675841	121902	
BS-12010-7						7	709634	125264			1943,1	788482	139182	
BS-12012-5	120	12	7,938	122,2	114,262	5	561873	108630	0,06	2241,4	1478,0	624303	120700	0,06
BS-12012-6						6	674247	127070			1762,6	749163	141189	
BS-12012-7						7	786622	145084			2045,6	874024	161204	
BS-12016-4	120	16	9,525	122,6	113,075	4	514622	112196	0,06	2213,8	1365,6	571802	124662	0,06
BS-12016-5						5	643278	135932			1692,0	714753	151035	
BS-12016-6						6	771933	159007			2015,8	857703	176674	
BS-12020-4	120	20	12,7	124,1	111,4	4	757704	178299	0,06	2185,4	1551,3	841893	198110	0,06
BS-12020-5						5	953662	217011			1932,1	1059624	241123	
BS-12020-6						6	1149620	254622			2309,8	1277355	282913	
BS-12040-3	120	40	12,7	124,1	111,4	3	559547	137971	0,06	2185,4	1259,2	621719	153301	0,06
BS-12040-4						4	754738	178066			1674,1	838598	197851	
BS-12040-5						5	949929	216727			2084,4	1055477	240808	

• Standard únicamente rosca derecha. Rosca izquierda bajo consulta.

• R_{s1}= Rigidez del eje del husillo a bolas en el caso de un extremo fijo y otro libre por 1m de longitud. Para el caso de los dos extremos fijos multiplicar por 4.

• R_{nu}= Rigidez de la tuerca para una carga de servicio media del 30% de la capacidad de carga dinámica y una calidad IT5.

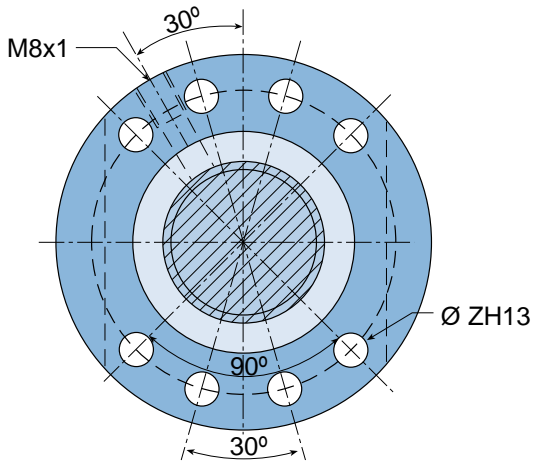

Diámetro Diameter	Paso Lead											
	4	5	6	8	10	12	16	20	25	32	40	64
50												
63												
80												
100												
120												

unidades en mm / units: mm

Dimensiones de la tuerca / Nut dimensions											Referencia Type
D	D ₁	D ₂	X	Y	L	L ₈	L ₉	Z	C	F	
125	145	165	22	74	96	130	147,5	13,5	11	16	BS-10010-4
				84	106						BS-10010-5
				95	117						BS-10010-6
125	145	165	22	86	108	130	147,5	13,5	11	20	BS-10012-4
				99	121						BS-10012-5
				111	133						BS-10012-6
150	176	202	30	106	136	155	178,5	17,5	15	25	BS-10016-4
				123	153						BS-10016-5
				139	169						BS-10016-6
150	176	202	30	128	158	155	178,5	17,5	15	25	BS-10020-4
				149	179						BS-10020-5
				170	200						BS-10020-6
150	176	202	30	137	167	155	178,5	17,5	15	45	BS-10040-3
				177	207						BS-10040-4
				217	247						BS-10040-5
150	176	202	25	84	109	155	178,5	17,5	12,5	16	BS-12010-5
				95	120						BS-12010-6
				105	130						BS-12010-7
150	176	202	25	99	124	155	178,5	17,5	12,5	20	BS-12012-5
				111	136						BS-12012-6
				124	149						BS-12012-7
170	196	222	30	106	136	175	198,5	17,5	15	25	BS-12016-4
				123	153						BS-12016-5
				139	169						BS-12016-6
170	196	222	30	128	158	175	198,5	17,5	15	25	BS-12020-4
				149	179						BS-12020-5
				170	200						BS-12020-6
170	196	222	30	140	170	175	198,5	17,5	15	45	BS-12040-3
				180	210						BS-12040-4
				220	250						BS-12040-5

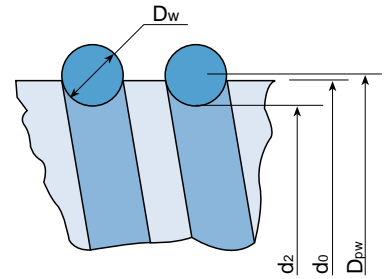

Detalle B
Detail B

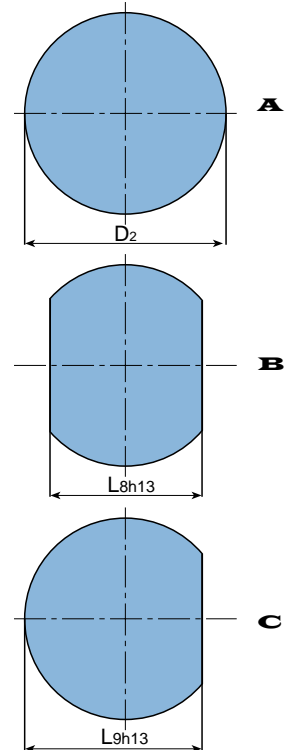

• Standard thread:RH only. Left-hand thread on request.

• R_{S1} = Rigidity of the ball screw shaft with one end fixed and one end free, per unit length of one metre. For two-end fixed systems, multiply by 4.

• R_{NU} = Rigidity of the nut for a working load equal to 30% of the dynamic load rating and for a tolerance grade of IT5.

Husillos a bolas rectificadas

Ground Ball Screws



Korta

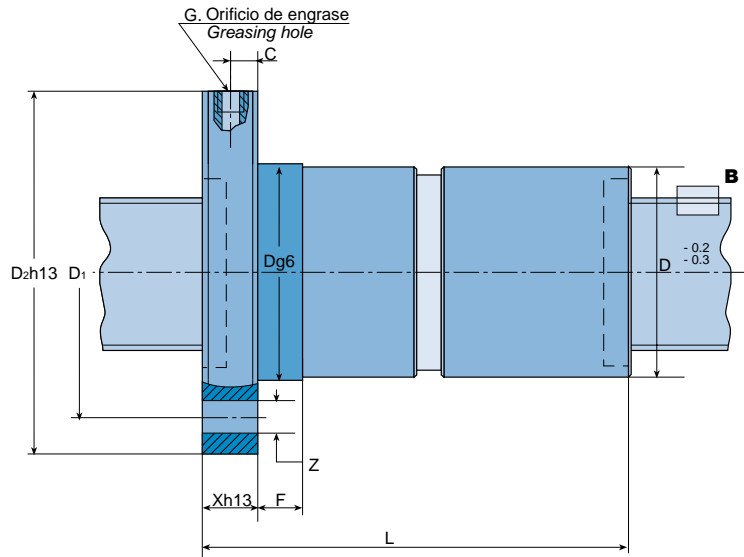

TUERCA DOBLE CON BRIDA

Tipo : DBS
DOUBLE NUT WITH FLANGE
Type: DBS

Referencia Type	Diámetro Diameter (d ₀)	Paso Lead (Ph)	Diam. bolas Ball diameter (D _w)	D _{pw}	d ₂	Circuitos Circuits (i)	Capacidad de carga Load rating		Rigidez / Rigidity		Dimensiones			
							C ₀ (N)	C _A (N)	R _{s1} (N/μm-m)	R _{nu} (N/μm)	D	D ₁	D ₂	X
DBS-1204-2	12	4	2,381	12,66	10,279	2	5591	3165	19,9	92,3	24	32	40	10
DBS-1204-3						3	8387	4485		136,0				
DBS-1204-4						4	11183	5744		179,0				
DBS-1205-2	12	5	2,381	12,66	10,279	2	5576	3162	19,9	92,8	24	32	40	10
DBS-1205-3						3	8364	4481		136,7				
DBS-1604-2	16	4	2,381	16,66	14,279	2	8660	4045	37,0	126,3	28	38	48	10
DBS-1604-3						3	12989	5732		186,1				
DBS-1604-4						4	17319	7341		244,9				
EDBS-1605	16	5	3,5	17	13,5	2	12090	6399	34,8	130,8	28	38	48	10
DBS-1605-3						3	18135	9069		192,8				
DBS-1605-4						4	24180	11615		253,8				
DBS-1610-2	16	10	3,5	17	13,5	2	11935	6372	34,8	132,9	28	38	48	10
DBS-1610-3						3	17903	9030		195,7				
DBS-1610-4						4	23871	11565		257,5				
DBS-2004-2	20	4	2,381	20,66	18,279	2	11218	4587	59,4	161,2	36	47	58	10
DBS-2004-3						3	16827	6501		237,6				
DBS-2004-4						4	22436	8326		312,8				
DBS-2005-2	20	5	3,5	21	17,5	2	15410	7309	56,6	160,0	36	47	58	10
EDBS-2005						3	23116	10359		235,7				
DBS-2005-4						4	30821	13267		310,3				
DBS-2010-2	20	10	3,5	21	17,5	2	16371	7632	56,6	165,9	36	47	58	10
DBS-2010-3						3	24557	10816		244,3				
DBS-2010-4						4	32743	13852		321,5				
DBS-2020-2	20	20	3,5	21	17,5	2	17959	8206	56,6	184,1	36	47	58	10

- Standard únicamente rosca derecha. Rosca izquierda bajo consulta.
- R_{s1}= Rigidez del eje del husillo a bolas en el caso de un extremo fijo y otro libre por 1m de longitud. Para el caso de los dos extremos fijos multiplicar por 4.
- R_{nu}=Rigidez de la tuerca con una precarga del 6% de la capacidad de carga dinámica y una calidad IT5.

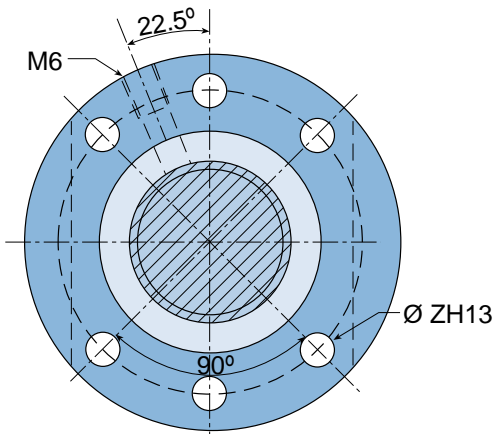

Diámetro Diameter	Paso Lead										
	4	5	6	8	10	12	16	20	25	32	40
12											
16											
20											
25											
32											
40											

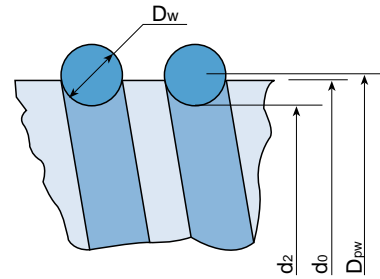

unidades en mm / units: mm

de la tuerca / Nut dimensions						Referencia Type
L	L8	L9	Z	C	F	
58	31	35,5	5,5	5	10	DBS-1204-2
68						DBS-1204-3
76						DBS-1204-4
66	31	35,5	5,5	5	10	DBS-1205-2
76						DBS-1205-3
58	40	44	5,5	5	10	DBS-1604-2
68						DBS-1604-3
76						DBS-1604-4
66	40	44	5,5	5	10	EDBS-1605
76						DBS-1605-3
86						DBS-1605-4
96	40	44	5,5	5	16	DBS-1610-2
124						DBS-1610-3
144						DBS-1610-4
58	44	51	6,6	5	10	DBS-2004-2
68						DBS-2004-3
76						DBS-2004-4
66	44	51	6,6	5	10	DBS-2005-2
76						EDBS-2005
86						DBS-2005-4
96	44	51	6,6	5	16	DBS-2010-2
124						DBS-2010-3
144						DBS-2010-4
131	44	51	6,6	5	25	DBS-2020-2

Detalle **B**
Detail **B**

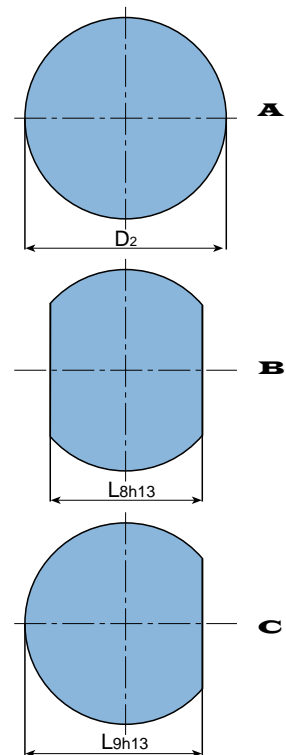

EDBS Tuerca de STOCK con brida tipo B
STOCK nut. Flange type B

- Standard thread RH only. Left-hand thread on request.
- R_{s1} = Rigidity of the ball screw shaft with one end fixed and one end free, per unit length of one metre. For two-end fixed systems, multiply by 4.
- R_{nu} = Rnu: Rigidity of the nut preloaded to 6% of the dynamic load rating and for a tolerance grade of IT5.

Husillos a bolas rectificados

Ground Ball Screws



Korta

TUERCA DOBLE CON BRIDA

Tipo : DBS

DOUBLE NUT WITH FLANGE

Type: DBS

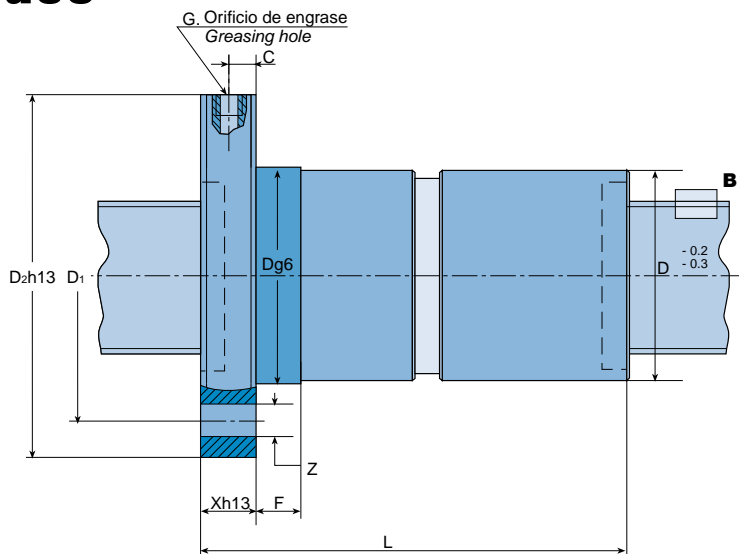

Referencia Type	Diámetro Diameter (d ₀)	Paso Lead (Ph)	Diam. bolas Ball diameter (D _w)	D _{pw}	d ₂	Circuitos Circuits (i)	Capacidad de carga Load rating		Rigidez / Rigidity		Dimensiones			
							C ₀ (N)	C _A (N)	R _{s1} (N/μm-m)	R _{nu} (N/μm)	D	D ₁	D ₂	X
DBS-2504-2	25	4	2,381	25,66	23,279	2	14287	5112	94,8	195,5	40	51	62	10
DBS-2504-3						3	21430	7244		288,3				
DBS-2504-4						4	28574	9278		379,7				
DBS-2505-2	25	5	3,5	26	22,5	2	20935	8612	91,3	201,6	40	51	62	10
EDBS-2505						3	31402	12205		297,2				
DBS-2505-4						4	41870	15632		391,4				
DBS-2506-2	25	6	3,969	26,3	22,331	2	22653	9848	91,0	198,5	40	51	62	10
DBS-2506-3						3	33980	13957		292,5				
DBS-2506-4						4	45307	17874		385,2				
DBS-2510-2	25	10	4,76	26,6	21,84	2	26355	12216	89,0	201,8	40	51	62	10
EDBS-2510						3	39532	17313		297,3				
DBS-2510-4						4	52710	22173		391,3				
EDBS-2520	25	20	3,5	26	22,5	2	23589	9411	91,3	231,6	40	51	62	10
DBS-2520-3						3	35383	13337		348,0				
DBS-2525-2	25	25	3,5	26	22,5	2	23222	9362	91,3	229,9	40	51	62	10
DBS-3204-3	32	4	2,381	32,66	30,279	3	29098	8334	158,2	359,0	50	65	80	12
DBS-3204-4						4	38797	10674		473,0				
DBS-3204-5						5	48496	12932		585,7				
DBS-3205-3	32	5	3,5	33	29,5	3	41348	13892	153,7	365,7	50	65	80	12
EDBS-3205						4	55131	17791		481,8				
DBS-3205-5						5	68913	21555		596,6				
DBS-3206-3	32	6	3,969	33,3	29,331	3	46769	16438	153,3	375,0	50	65	80	12
DBS-3206-4						4	62358	21052		493,9				
DBS-3206-5						5	77948	25506		611,5				
DBS-3208-3	32	8	4,762	33,6	28,838	3	55016	20701	150,7	382,9	50	65	80	12
DBS-3208-4						4	73355	26512		504,2				
DBS-3208-5						5	91694	32121		624,2				
EDBS-3210	32	10	6,35	34,1	27,75	3	65122	27753	144,6	358,5	50	65	80	12
DBS-3210-4						4	86829	35543		472,0				
DBS-3210-5						5	108537	43063		584,3				
DBS-3220-2	32	20	3,969	33,3	29,331	2	33463	12225	153,3	288,4	50	65	80	12
EDBS-3220						3	51590	17645		436,1				
EDBS-3232						2	33937	12450		153,3				

• Standard unicamente rosca derecha. Rosca izquierda bajo consulta.

• R_{s1}= Rigidez del eje del husillo a bolas en el caso de un extremo fijo y otro libre por 1m de longitud. Para el caso de los dos extremos fijos multiplicar por 4.

• R_{nu}=Rigidez de la tuerca con una precarga del 6% de la capacidad de carga dinámica y una calidad IT5.

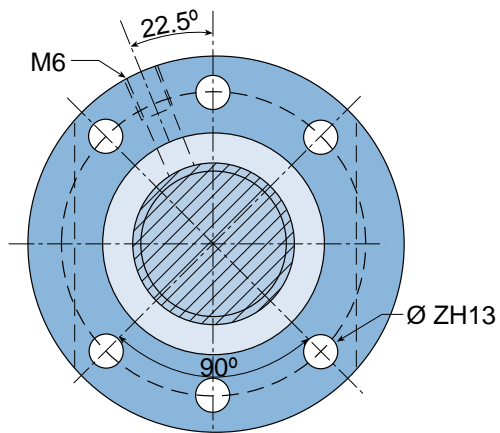

Diámetro Diameter	Paso Lead										
	4	5	6	8	10	12	16	20	25	32	40
12											
16											
20											
25	■	■	■		■			■	■		
32	■	■	■	■	■			■		■	
40											

unidades en mm / units: mm

de la tuerca / Nut dimensions						Referencia Type
L	L ₈	L ₉	Z	C	F	
58						DBS-2504-2
68	48	55	6,6	5	10	DBS-2504-3
76						DBS-2504-4
66						DBS-2505-2
76	48	55	6,6	5	10	EDBS-2505
86						DBS-2505-4
74						DBS-2506-2
92	48	55	6,6	5	10	DBS-2506-3
104						DBS-2506-4
98						DBS-2510-2
120	48	55	6,6	5	16	EDBS-2510
144						DBS-2510-4
133						EDBS-2520
173	48	55	6,6	5	25	DBS-2520-3
151	48	55	6,6	5	30	DBS-2525-2
70						DBS-3204-3
78	62	71	9	6	10	DBS-3204-4
86						DBS-3204-5
78						DBS-3205-3
88	62	71	9	6	10	EDBS-3205
98						DBS-3205-5
94						DBS-3206-3
106	62	71	9	6	10	DBS-3206-4
120						DBS-3206-5
110						DBS-3208-3
126	62	71	9	6	16	DBS-3208-4
142						DBS-3208-5
133						EDBS-3210
155	62	71	9	6	16	DBS-3210-4
175						DBS-3210-5
143						DBS-3220-2
183	62	71	9	6	25	EDBS-3220
187	62	71	9	6	40	EDBS-3232

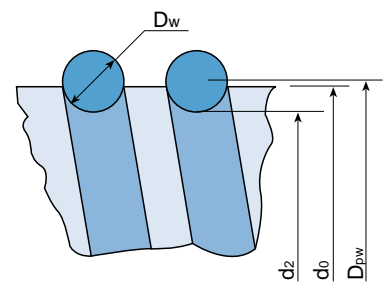

Detalle B
Detail B

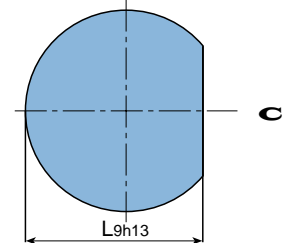
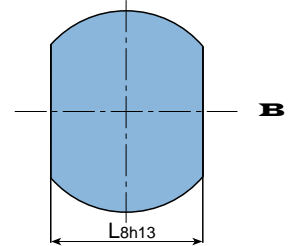
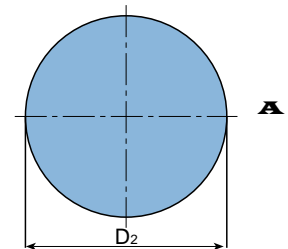

EDBS Tuerca de STOCK con brida tipo B
STOCK nut. Flange type B

- Standard thread RH only. Left-hand thread on request.
- R_{S1} = Rigidity of the ball screw shaft with one end fixed and one end free, per unit length of one metre. For two-end fixed systems, multiply by 4.
- R_{nu} = Rnu: Rigidity of the nut preloaded to 6% of the dynamic load rating and for a tolerance grade of IT5.

Husillos a bolas rectificados

Ground Ball Screws



Korta

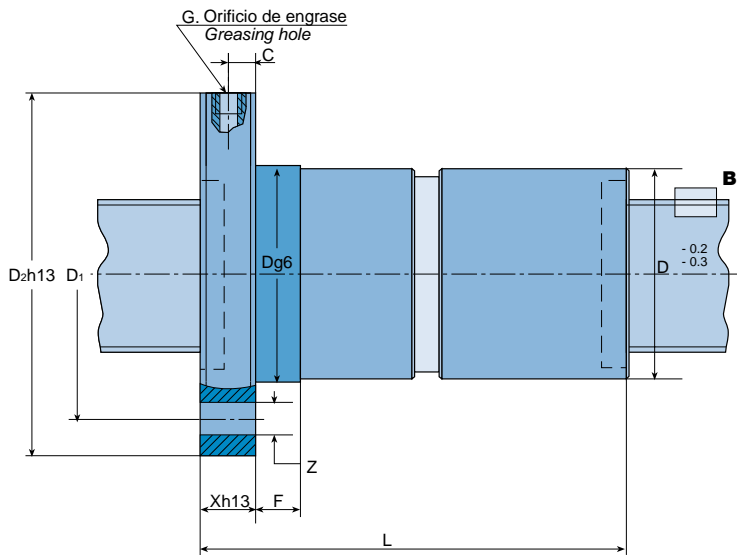

TUERCA DOBLE CON BRIDA

Tipo : DBS

DOUBLE NUT WITH FLANGE

Type: DBS

Referencia Type	Diámetro Diameter (d ₀)	Paso Lead (Ph)	Diam. bolas Ball diameter (D _w)	D _{pw}	d ₂	Circuitos Circuits (i)	Capacidad de carga Load rating		Rigidez / Rigidity		Dimensiones			
							C ₀ (N)	C _A (N)	R _{s1} (N/μm·m)	R _{nu} (N/μm)	D	D ₁	D ₂	X
DBS-4005-3	40	5	3,5	41	37,5	3	52947	15508	244,7	440,6	63	78	93	14
DBS-4005-4						4	70596	19861		580,5				
EDBS-4005						5	88245	24062		718,9				
DBS-4005-6						6	105894	28147		856,2				
DBS-4006-3	40	6	3,969	41,3	37,331	3	59558	18337	244,3	451,4	63	78	93	14
DBS-4006-4						4	79411	23485		594,6				
DBS-4006-5						5	99263	28453		736,3				
DBS-4006-6						6	119116	33283		876,8				
DBS-4008-3	40	8	4,762	41,6	36,838	3	70368	23284	241,0	465,0	63	78	93	14
DBS-4008-4						4	93825	29820		612,3				
DBS-4008-5						5	117281	36128		758,1				
DBS-4008-6						6	140737	42261		902,6				
DBS-4010-3	40	10	6,35	42,1	35,75	3	86959	32514	233,3	454,6	63	78	93	14
EDBS-4010						4	115945	41641		598,6				
DBS-4010-5						5	144931	50450		741,0				
DBS-4010-6						6	173917	59014		882,1				
DBS-4012-3	40	12	6,35	42,1	35,75	3	86850	32500	233,3	459,2	63	78	93	14
DBS-4012-4						4	115800	41623		604,6				
DBS-4012-5						5	144750	50429		748,3				
DBS-4020-2	40	20	6,35	40,1	33,75	2	64596	24955	209,1	340,0	63	78	93	14
EDBS-4020						3	100483	36235		517,3				
DBS-4020-4						4	136370	46957		691,7				
EDBS-4040						2	62338	24661		209,1				

• Standard únicamente rosca derecha. Rosca izquierda bajo consulta.

• R_{s1}= Rigidez del eje del husillo a bolas en el caso de un extremo fijo y otro libre por 1m de longitud. Para el caso de los dos extremos fijos multiplicar por 4.

• R_{nu}=Rigidez de la tuerca con una precarga del 6% de la capacidad de carga dinámica y una calidad IT5.

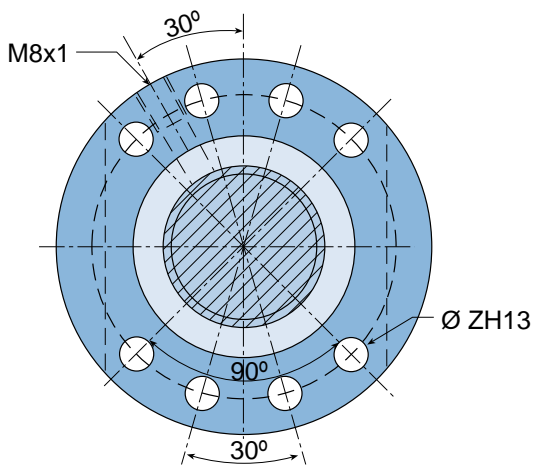

Diámetro Diameter	Paso Lead											
	4	5	6	8	10	12	16	20	25	32	40	
12												
16												
20												
25												
32												
40												

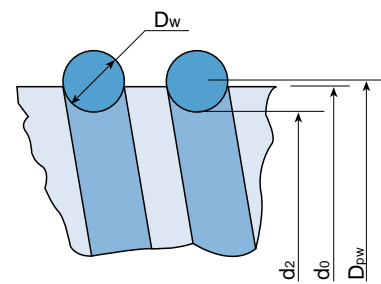

unidades en mm / units: mm

de la tuerca / Nut dimensions						Referencia Type
L	L8	L9	Z	C	F	
80	70	81,5	9	7	10	DBS-4005-3
90						DBS-4005-4
100						EDBS-4005
114						DBS-4005-6
96	70	81,5	9	7	10	DBS-4006-3
108						DBS-4006-4
122						DBS-4006-5
136						DBS-4006-6
112	70	81,5	9	7	16	DBS-4008-3
128						DBS-4008-4
144						DBS-4008-5
162						DBS-4008-6
135	70	81,5	9	7	16	DBS-4010-3
157						EDBS-4010
177						DBS-4010-5
199						DBS-4010-6
149	70	81,5	9	7	20	DBS-4012-3
175						DBS-4012-4
199						DBS-4012-5
149	70	81,5	9	7	25	DBS-4020-2
189						EDBS-4020
229						DBS-4020-4
225	70	81,5	9	7	45	EDBS-4040

Detalle **B**
Detail **B**

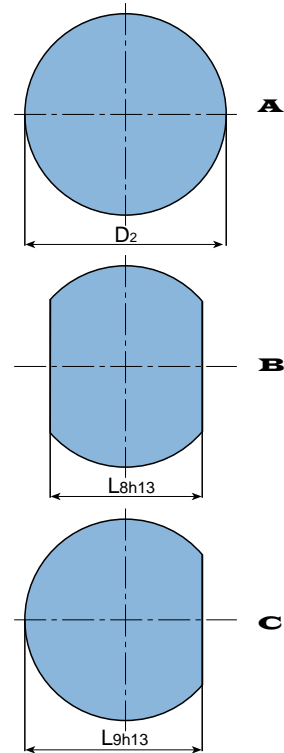

EDBS Tuerca de STOCK con brida tipo **B**
STOCK nut. Flange type **B**

- Standard thread RH only. Left-hand thread on request.
- R_{s1} = Rigidity of the ball screw shaft with one end fixed and one end free, per unit length of one metre. For two-end fixed systems, multiply by 4.
- R_{nu} = R_{nu} : Rigidity of the nut preloaded to 6% of the dynamic load rating and for a tolerance grade of IT5.

Husillos a bolas rectificadas

Ground Ball Screws



Korta

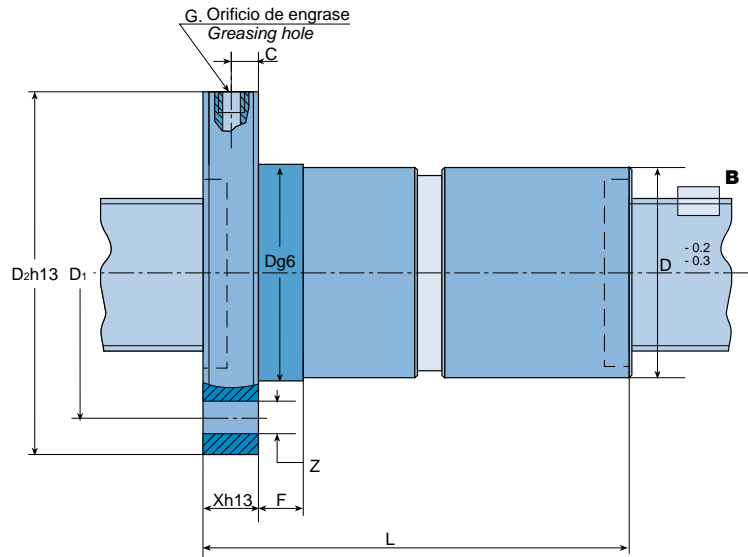

TUERCA DOBLE CON BRIDA

Tipo : DBS

DOUBLE NUT WITH FLANGE

Type: DBS

Referencia Type	Diámetro Diameter (d_0)	Paso Lead (Ph)	Diam. bolas Ball diameter (D_w)	D_{pw}	d_2	Circuitos Circuits (i)	Capacidad de carga Load rating		Rigidez / Rigidity		Dimensiones					
							C_0 (N)	C_A (N)	R_{S1} (N/ μ m-m)	R_{Nu} (N/ μ m)	D	D_1	D_2	X		
DBS-5005-3	50	5	3,5	51	47,5	3	67857	17254	388,3	521,4	75	93	110	16		
DBS-5005-4						4	90475	22098							687,1	
EDBS-5005						5	113094	26772								851,2
DBS-5005-6						6	135713	31317								
DBS-5006-3	50	6	3,969	51,3	47,331	3	76603	20495	387,8	538,2	75	93	110	16		
DBS-5006-4						4	102138	26248							709,2	
DBS-5006-5						5	127672	31801								878,4
DBS-5006-6						6	153207	37200								
DBS-5008-3	50	8	4,762	51,6	46,838	3	91845	26377	383,6	564,9	75	93	110	16		
DBS-5008-4						4	122460	33782							744,2	
DBS-5008-5						5	153075	40928								921,5
DBS-5008-6						6	183690	47876								
DBS-5010-3	50	10	7,144	52	44,856	3	123944	42707	363,5	548,7	75	93	110	16		
DBS-5010-4						4	165259	54694							722,7	
EDBS-5010						5	206574	66265								894,8
DBS-5010-6						6	247889	77514								
DBS-5012-3	50	12	7,938	52,2	44,262	3	135915	48668	357,9	554,6	75	93	110	16		
DBS-5012-4						4	181219	62328							730,4	
DBS-5012-5						5	226524	75514								904,2
DBS-5016-2	50	16	7,144	50	42,856	2	82390	30105	333,2	383,9	75	93	110	16		
DBS-5016-3						3	123585	42665							565,6	
DBS-5016-4						4	164780	54641								744,6
DBS-5016-5						5	205975	66201								
DBS-5020-3	50	20	7,144	50	42,856	3	141431	47099	333,2	625,6	75	93	110	16		
DBS-5020-4						4	191616	60967							835,3	
EDBS-5020						5	241802	74333								1042,4
DBS-5040-2	50	40	7,144	50	42,856	2	89138	32263	333,2	414,4	75	93	110	16		

• Standard unicamente rosca derecha. Rosca izquierda bajo consulta.

• R_{S1} = Rigidez del eje del husillo a bolas en el caso de un extremo fijo y otro libre por 1m de longitud. Para el caso de los dos extremos fijos multiplicar por 4.

• R_{Nu} =Rigidez de la tuerca con una precarga del 6% de la capacidad de carga dinámica y una calidad IT5.

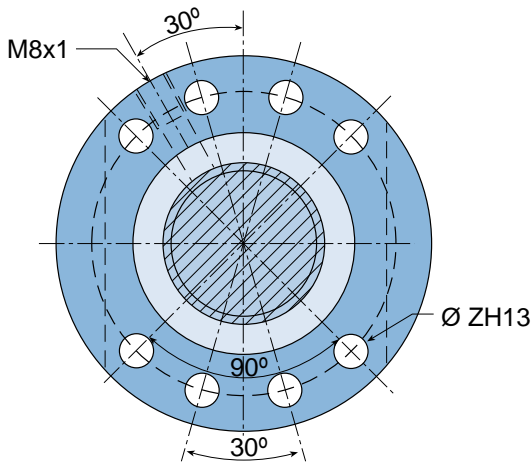

Diámetro Diameter	Paso Lead											
	4	5	6	8	10	12	16	20	25	32	40	50
50												
63												
80												
100												
120												

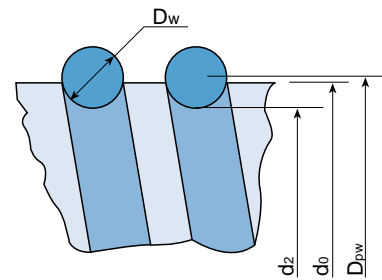

Detalle B
Detail B

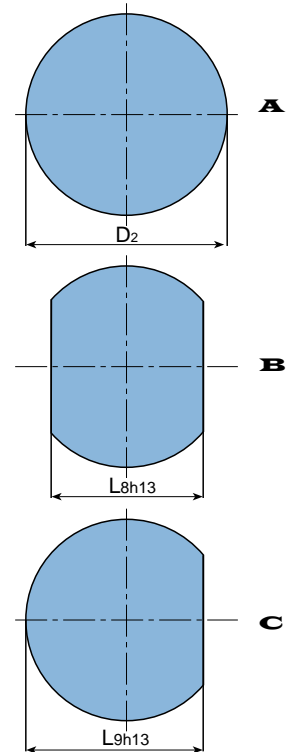

EDBS Tuerca de STOCK con brida tipo B
STOCK nut. Flange type B

unidades en mm / units: mm

de la tuerca / Nut dimensions						Referencia Type
L	L8	L9	Z	C	F	
82	85	97,5	11	8	10	DBS-5005-3
92						DBS-5005-4
102						EDBS-5005
116						DBS-5005-6
98	85	97,5	11	8	10	DBS-5006-3
110						DBS-5006-4
124						DBS-5006-5
138						DBS-5006-6
114	85	97,5	11	8	16	DBS-5008-3
130						DBS-5008-4
146						DBS-5008-5
164						DBS-5008-6
137	85	97,5	11	8	16	DBS-5010-3
159						DBS-5010-4
179						EDBS-5010
201						DBS-5010-6
157	85	97,5	11	8	20	DBS-5012-3
183						DBS-5012-4
209						DBS-5012-5
136	85	97,5	11	8	25	DBS-5016-2
168						DBS-5016-3
200						DBS-5016-4
232						DBS-5016-5
191	85	97,5	11	8	25	DBS-5020-3
231						DBS-5020-4
271						EDBS-5020
229	85	97,5	11	8	45	DBS-5040-2

- Standard thread RH only. Left-hand thread on request.
- R_{s1} = Rigidity of the ball screw shaft with one end fixed and one end free, per unit length of one metre. For two-end fixed systems, multiply by 4.
- R_{nu} = R_{nu} : Rigidity of the nut preloaded to 6% of the dynamic load rating and for a tolerance grade of IT5.

Husillos a bolas rectificadas

Ground Ball Screws



Korta

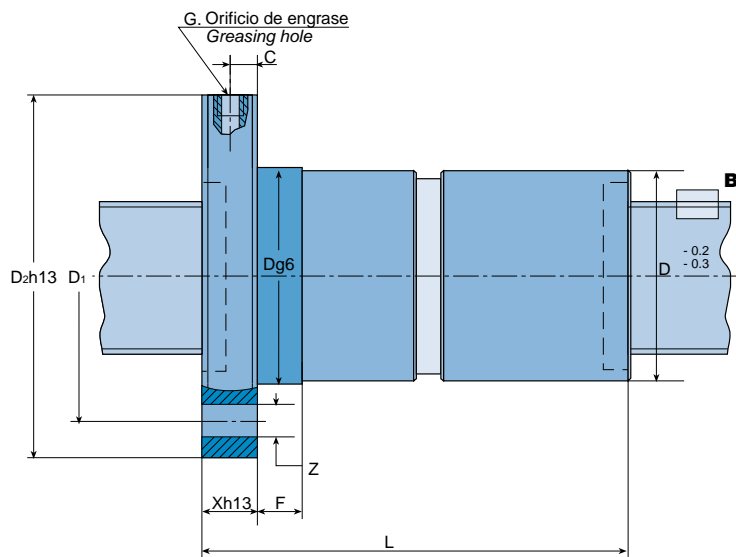

TUERCA DOBLE CON BRIDA

Tipo : DBS

DOUBLE NUT WITH FLANGE

Type: DBS

Referencia Type	Diámetro Diameter (d ₀)	Paso Lead (Ph)	Diam. bolas Ball diameter (Dw)	D _{pw}	d ₂	Circuitos Circuits (i)	Capacidad de carga Load rating		Rigidez / Rigidity		Dimensiones			
							C ₀ (N)	C _A (N)	R _{s1} (N/μm-m)	R _{nu} (N/μm)	D	D ₁	D ₂	X
DBS-6305-3	63	5	3,5	64	60,5	3	87733	19217	624,2	613,2	90	108	125	18
DBS-6305-4						4	116977	24611		808,7				
EDBS-6305						5	146221	29818		1002,2				
DBS-6305-6						6	175465	34879		1194,2				
DBS-6306-3	63	6	3,969	64,3	60,331	3	97907	22687	623,6	631,3	90	108	125	18
DBS-6306-4						4	130542	29055		832,3				
DBS-6306-5						5	163178	35201		1031,2				
DBS-6306-6						6	195813	41177		1228,5				
DBS-6310-3	63	10	7,144	65	57,856	3	165370	49250	592,6	676,8	90	108	125	18
DBS-6310-4						4	220494	63074		891,6				
EDBS-6310						5	275617	76418		1104,3				
DBS-6310-6						6	330741	89390		1315,1				
DBS-6312-3	63	12	7,938	65,2	57,262	3	178559	55757	585,5	679,1	90	108	125	18
DBS-6312-4						4	238078	71407		894,6				
DBS-6312-5						5	297598	86514		1107,7				
DBS-6312-6						6	357117	101200		1319,1				
DBS-6316-3	63	16	7,144	65	57,856	3	183403	52801	592,6	706,6	95	115	135	20
DBS-6316-4						4	247594	68184		940,0				
DBS-6316-5						5	311785	83016		1170,8				
DBS-6316-6						6	375976	97426		1399,5				
DBS-6320-3	63	20	7,144	65	57,856	3	183089	52771	592,6	787,7	95	115	135	20
DBS-6320-4						4	247170	68145		1047,9				
EDBS-6320						5	311251	82969		1305,1				
DBS-6320-6						6	375332	97371		1560,0				
DBS-6340-2	63	40	7,144	65	57,856	2	121860	37369	592,6	537,2	95	115	135	20
DBS-6340-3						3	187304	53829		808,4				

• Standard únicamente rosca derecha. Rosca izquierda bajo consulta.

• R_{s1}= Rigidez del eje del husillo a bolas en el caso de un extremo fijo y otro libre por 1m de longitud. Para el caso de los dos extremos fijos multiplicar por 4.

• R_{nu}=Rigidez de la tuerca con una precarga del 6% de la capacidad de carga dinámica y una calidad IT5.

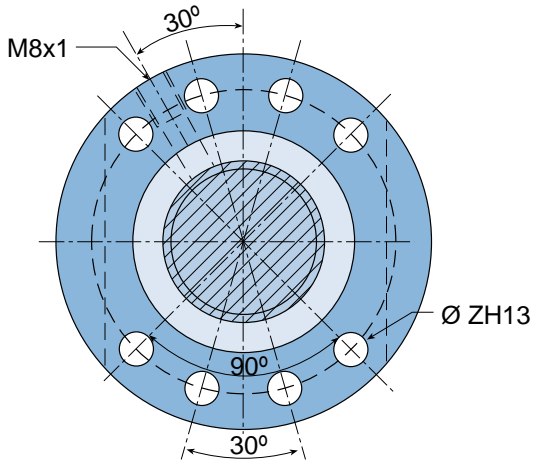

Diámetro Diameter	Paso Lead											
	4	5	6	8	10	12	16	20	25	32	40	64
50												
63												
80												
100												
120												

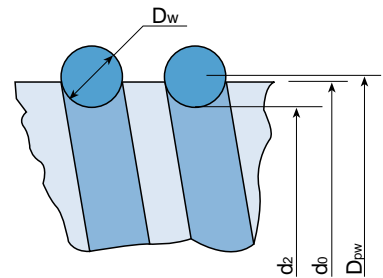

Detalle **B**
Detail **B**

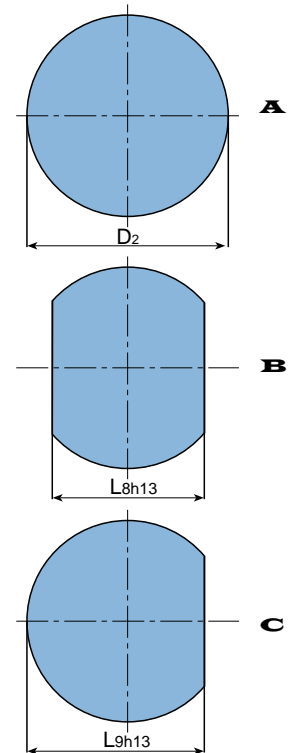

EDBS Tuerca de STOCK con brida tipo **B**
STOCK nut. Flange type **B**

unidades en mm / units: mm

de la tuerca / Nut dimensions						Referencia Type
L	L8	L9	Z	C	F	
84	95	110	11	9	10	DBS-6305-3
94						DBS-6305-4
104						EDBS-6305
118						DBS-6305-6
100	95	110	11	9	10	DBS-6306-3
112						DBS-6306-4
126						DBS-6306-5
140						DBS-6306-6
139	95	110	11	9	16	DBS-6310-3
161						DBS-6310-4
181						EDBS-6310
203						DBS-6310-6
159	95	110	11	9	20	DBS-6312-3
185						DBS-6312-4
211						DBS-6312-5
235						DBS-6312-6
169	100	117,5	13,5	10	25	DBS-6316-3
201						DBS-6316-4
233						DBS-6316-5
265						DBS-6316-6
193	100	117,5	13,5	10	25	DBS-6320-3
233						DBS-6320-4
273						EDBS-6320
313						DBS-6320-6
231	100	117,5	13,5	10	45	DBS-6340-2
311						DBS-6340-3

• Standard thread RH only. Left-hand thread on request.

• R_{s1} = Rigidity of the ball screw shaft with one end fixed and one end free, per unit length of one metre. For two-end fixed systems, multiply by 4.

• R_{nu} = R_{nu} : Rigidity of the nut preloaded to 6% of the dynamic load rating and for a tolerance grade of IT5.

Husillos a bolas rectificados

Ground Ball Screws

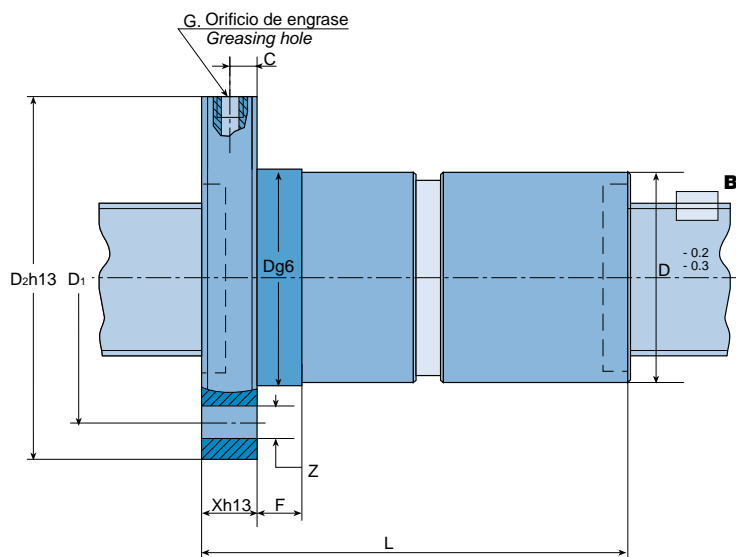

TUERCA DOBLE CON BRIDA

Tipo : DBS

DOUBLE NUT WITH FLANGE

Type: DBS

Referencia Type	Diámetro Diameter (d ₀)	Paso Lead (Ph)	Diam. bolas Ball diameter (Dw)	D _{pw}	d ₂	Circuitos Circuits (i)	Capacidad de carga Load rating		Rigidez / Rigidity		Dimensiones			
							C ₀ (N)	C _A (N)	R _{S1} (N/μm-m)	R _{nu} (N/μm)	D	D ₁	D ₂	X
DBS-8010-4	80	10	7,144	82	74,856	4	294122	72122	976,4	1059,6	105	125	145	20
DBS-8010-5						5	367653	87380		1313,1				
EDBS-8010						6	441184	102213		1564,5				
DBS-8012-4	80	12	7,938	82,2	74,262	4	317639	81878	967,3	1072,3	105	125	145	20
DBS-8012-5						5	397049	99199		1328,4				
DBS-8012-6						6	476459	116039		1582,6				
DBS-8016-4	80	16	9,525	82,6	73,075	4	359047	100996	949,1	1130,6	125	145	165	25
DBS-8016-5						5	448808	122362		1399,7				
DBS-8016-6						6	538570	143133		1666,4				
DBS-8020-3	80	20	9,525	82,6	73,075	3	313832	87364	949,1	989,8	125	145	165	25
DBS-8020-4						4	423877	112854		1317,3				
EDBS-8020						5	533922	137429		1641,1				
DBS-8020-6						6	643966	161303		1962,0				
DBS-8040-2	80	40	9,525	82,6	73,075	2	202005	60395	949,1	675,0	125	145	165	25
DBS-8040-3						3	311088	87109		1016,9				
DBS-8040-4						4	420171	112524		1353,3				
DBS-8064-2	80	64	9,525	82,6	73,075	2	206383	61629	949,1	680,3	125	145	165	25

• Standard unicamente rosca derecha. Rosca izquierda bajo consulta.

• R_{S1}= Rigidez del eje del husillo a bolas en el caso de un extremo fijo y otro libre por 1m de longitud. Para el caso de los dos extremos fijos multiplicar por 4.

• R_{nu}=Rigidez de la tuerca con una precarga del 6% de la capacidad de carga dinámica y una calidad IT5.

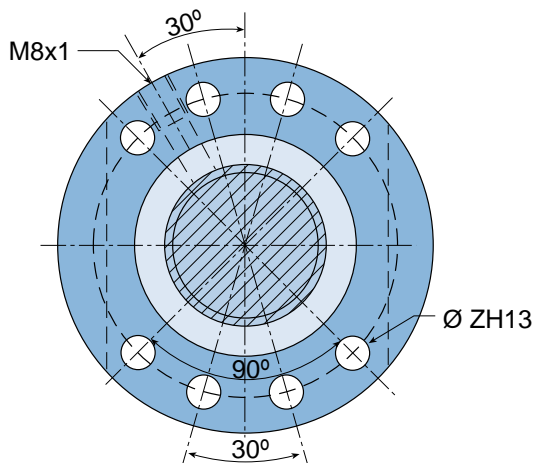

Diámetro Diameter	Paso Lead											
	4	5	6	8	10	12	16	20	25	32	40	64
50												
63												
80												
100												
120												

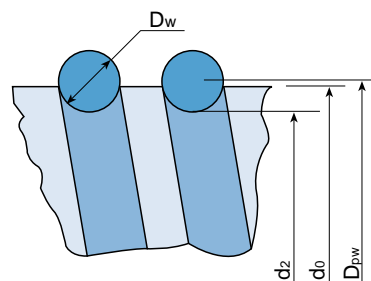

Detalle **B**
Detail **B**

unidades en mm / units: mm

de la tuerca / Nut dimensions						Referencia Type
L	L ₈	L ₉	Z	C	F	
163	110	127,5	13,5	10	16	DBS-8010-4
183						DBS-8010-5
205						EDBS-8010
187	110	127,5	13,5	10	20	DBS-8012-4
213						DBS-8012-5
237						DBS-8012-6
207	130	147,5	13,5	12,5	25	DBS-8016-4
239						DBS-8016-5
271						DBS-8016-6
196	130	147,5	13,5	12,5	25	DBS-8020-3
236						DBS-8020-4
276						EDBS-8020
316						DBS-8020-6
237	130	147,5	13,5	12,5	45	DBS-8040-2
317						DBS-8040-3
397						DBS-8040-4
327	130	147,5	13,5	12,5	70	DBS-8064-2

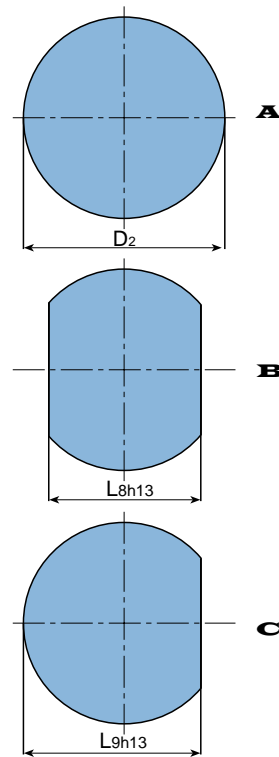

EDBS Tuerca de STOCK con brida tipo **B**
STOCK nut. Flange type **B**

- Standard thread RH only. Left-hand thread on request.
- R_{s1} = Rigidity of the ball screw shaft with one end fixed and one end free, per unit length of one metre. For two-end fixed systems, multiply by 4.
- R_{nu} = R_{nu} : Rigidity of the nut preloaded to 6% of the dynamic load rating and for a tolerance grade of IT5.

Husillos a bolas rectificadas

Ground Ball Screws



Korta

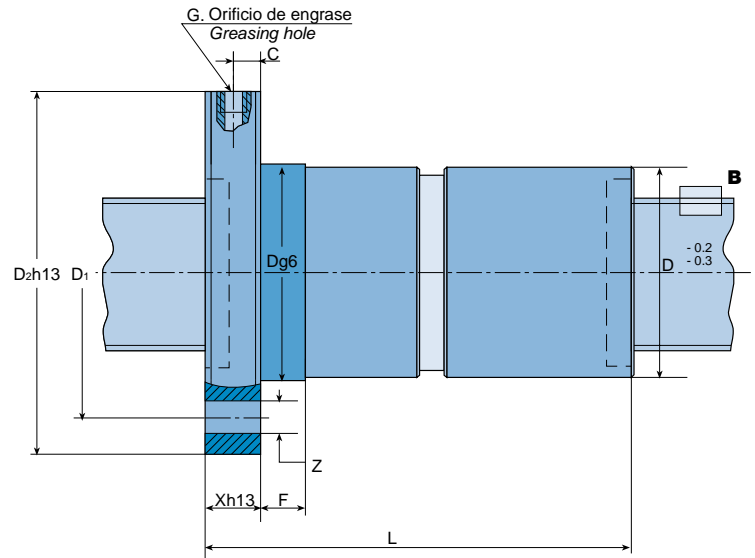

TUERCA DOBLE CON BRIDA
Tipo : DBS
DOUBLE NUT WITH FLANGE
Type: DBS

Referencia Type	Diámetro Diameter (d ₀)	Paso Lead (Ph)	Diam. bolas Ball diameter (D _w)	D _{pw}	d ₂	Circuitos Circuits (i)	Capacidad de carga Load rating		Rigidez / Rigidity		Dimensiones			
							C ₀ (N)	C _A (N)	R _{s1} (N/μm-m)	R _{nu} (N/μm)	D	D ₁	D ₂	X
DBS-10010-4	100	10	7,144	102	94,856	4	367751	78957	1549,9	1188,0	125	145	165	22
DBS-10010-5						5	459689	95661		1472,9				
DBS-10010-6						6	551626	111900		1755,7				
DBS-10012-4	100	12	7,938	102,2	94,262	4	408549	91497	1538,4	1236,6	125	145	165	22
DBS-10012-5						5	510686	110853		1532,9				
DBS-10012-6						6	612823	129672		1826,9				
DBS-10016-4	100	16	9,525	102,6	93,075	4	457273	112537	1515,5	1351,3	150	176	202	30
DBS-10016-5						5	571592	136345		1673,1				
DBS-10016-6						6	685910	159490		1992,2				
DBS-10020-4	100	20	9,525	102,6	93,075	4	522237	122986	1515,5	1534,2	150	176	202	30
DBS-10020-5						5	656876	149625		1909,2				
DBS-10020-6						6	791516	175507		2280,9				
DBS-10040-3	100	40	9,525	102,6	93,075	3	397557	97174	1515,5	1206,4	150	176	202	30
DBS-10040-4						4	535485	125296		1602,0				
DBS-10040-5						5	673413	152416		1993,1				
DBS-10064-2	100	64	9,525	102,6	93,075	2	256611	67367	1515,5	810,0	150	176	202	30
DBS-12010-5	120	10	7,144	122	114,856	5	563201	104211	2255,4	1694,4	150	176	202	25
DBS-12010-6						6	675841	121902		2020,0				
DBS-12010-7						7	788482	139182		2343,8				
DBS-12012-5	120	12	7,938	122,2	113,262	5	624303	120700	2241,4	1747,2	150	176	202	25
DBS-12012-6						6	749163	141189		2082,6				
DBS-12012-7						7	874024	161204		2415,9				
DBS-12016-4	120	16	9,525	122,6	113,075	4	571802	124662	2213,8	1576,0	170	196	222	30
DBS-12016-5						5	714753	151035		1951,9				
DBS-12016-6						6	857703	176674		2324,7				
DBS-12020-4	120	20	12,7	124,1	111,4	4	841893	198110	2185,4	1789,4	170	196	222	30
DBS-12020-5						5	1059624	241123		2228,3				
DBS-12020-6						6	1277355	282913		2663,4				
DBS-12040-3	120	40	12,7	124,1	111,4	3	621719	153301	2185,4	1422,8	170	196	222	30
DBS-12040-4						4	838598	197851		1891,4				
DBS-12040-5						5	1055477	240808		2354,7				
DBS-12064-2	120	64	12,7	124,1	111,4	2	415933	108714	2185,4	969,9	170	196	222	30

• Standard únicamente rosca derecha. Rosca izquierda bajo consulta.

• R_{s1}= Rigidez del eje del husillo a bolas en el caso de un extremo fijo y otro libre por 1m de longitud. Para el caso de los dos extremos fijos multiplicar por 4.

• R_{nu}=Rigidez de la tuerca con una precarga del 6% de la capacidad de carga dinámica y una calidad IT5.

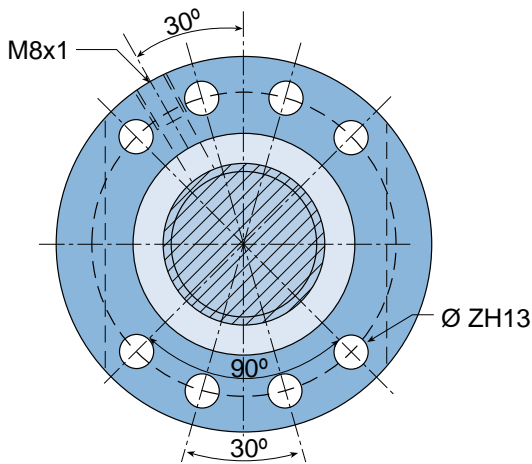

Diámetro Diameter	Paso Lead											
	4	5	6	8	10	12	16	20	25	32	40	64
50												
63												
80												
100												
120												

unidades en mm / units: mm

de la tuerca / Nut dimensions						Referencia Type
L	L ₈	L ₉	Z	C	F	
165						DBS-10010-4
185	130	147,5	13,5	11	16	DBS-10010-5
207						DBS-10010-6
189						DBS-10012-4
215	130	147,5	13,5	11	20	DBS-10012-5
239						DBS-10012-6
237						DBS-10016-4
271	155	178,5	17,5	15	25	DBS-10016-5
303						DBS-10016-6
281						DBS-10020-4
323	155	178,5	17,5	15	25	DBS-10020-5
365						DBS-10020-6
319						DBS-10040-3
399	155	178,5	17,5	15	45	DBS-10040-4
479						DBS-10040-5
331	155	178,5	17,5	15	70	DBS-10064-2
188						DBS-12010-5
210	155	178,5	17,5	12,5	16	DBS-12010-6
230						DBS-12010-7
218						DBS-12012-5
242	155	178,5	17,5	12,5	20	DBS-12012-6
268						DBS-12012-7
237						DBS-12016-4
271	175	198,5	17,5	15	25	DBS-12016-5
303						DBS-12016-6
281						DBS-12020-4
323	175	198,5	17,5	15	25	DBS-12020-5
365						DBS-12020-6
325						DBS-12040-3
405	175	198,5	17,5	15	45	DBS-12040-4
485						DBS-12040-5
337	175	198,5	17,5	15	70	DBS-12064-2

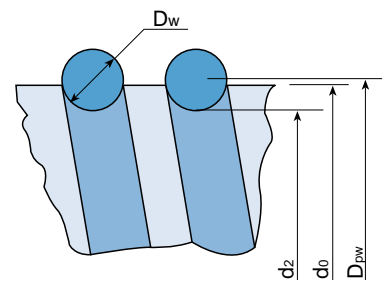

Detalle **B**
Detail **B**

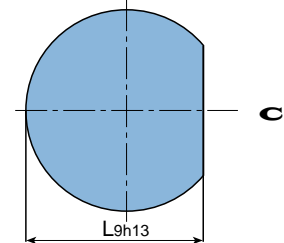
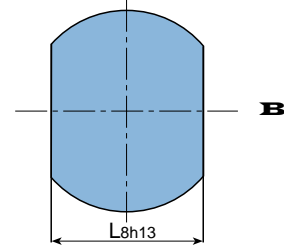
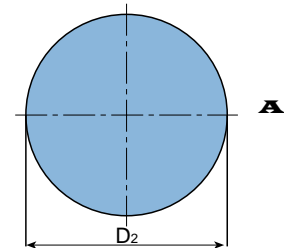

- Standard thread RH only. Left-hand thread on request.
- R_{S1} = Rigidity of the ball screw shaft with one end fixed and one end free, per unit length of one metre. For two-end fixed systems, multiply by 4.
- R_{nu} = R_{nu} : Rigidity of the nut preloaded to 6% of the dynamic load rating and for a tolerance grade of IT5.



Actualizaciones en Internet

Updates in Internet

PRODUCT CATALOGUE - PRODUCT RANGE

We offer to the market a wide range of precision ball screws in a whole variety of diameters and leads.

See: [Conventional catalogues](#), [Technical catalogues](#), [Dimensional catalogues](#)

Download: , , 

Language: Spanish and English, Spanish and English, German and French

An Adobe Acrobat Reader is required for the correct viewing of these documents. 

Diameter	4	5	6	8	10	12	16	20	25	32	40	50	64
10	■	■											
15			■										
20			■	■									
25				■	■								
32					■	■							
40						■	■						
50							■	■					
64								■	■				
80									■	■			
100										■	■		
120											■	■	
160												■	■

■ DDY standard leads

The table shows KORTA's standard range of ball screws. For any other sizes, please consult our Engineering Department.

PRECISION DEGREES

DIN/ISO		IT1	IT2	IT3	IT5	IT7	IT8
JIS	E8	E1	E3		E5	E7	
ISO (Sw)	3.3	5	6	8	12	18	22

Copyright © All Rights Reserved. KORTA 2000-2004. WEB MAP. SPANISH

<http://www.korta.com/update.html>



**SITUACION
LOCATION**





Korta

Joxe Mari Korta Industriegunea, 2
Apdo. 6
E-20750 ZUMAIA (Gipuzkoa - Spain)
Tfnos. (0034) 943 860362/66
Fax (0034) 943 860142
E-mail: info@korta.com
<http://www.korta.com>

